

JVC

SERVICE MANUAL

CASSETTE RECEIVER

KS-F171G

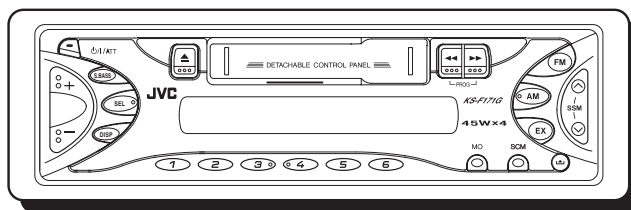
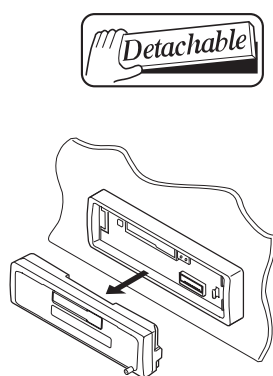

Area Suffix
UN ----- Asean

TABLE OF CONTENTS

1	PRECAUTIONS	1-3
2	SPECIFIC SERVICE INSTRUCTIONS	1-4
3	DISASSEMBLY	1-5
4	ADJUSTMENT	1-13
5	TROUBLE SHOOTING	1-17

SPECIFICATION

BAGIAN AMPLIFIER AUDIO	Output power maksimum	Depan	45 watt per chanel
		Belakang	45 watt per chanel
	Output Power kontinyu (RMS)	Depan	17 watt per chanel dalam 4 Ω , 40 Hz hingga 20 000 Hz dengan tidak lebih dari 0.8% distorsi harmonis total.
		Belakang	17 watt per chanel dalam 4 Ω , 40 Hz hingga 20 000 Hz dengan tidak lebih dari 0.8% distorsi harmonis total.
	Impedansi beban		4 Ω (toleransi antara 4 Ω hingga 8 Ω)
	Batas tone kontrol	Bass	± 10 dB pada 100 Hz
		Treble	± 10 dB pada 10 kHz
	Respon Frekuensi		40 Hz hingga 20 000 Hz
	Rasio Sinyal ke suara		70 dB
	Level Line-Out/ impedansi		1.0V/beban 20 k Ω (250 nWb/m)
Bagian Radio	Batas Frekuensi	FM	87.5 MHz hingga 108.0 MHz
		AM	531 kHz hingga 1 602 kHz
	[Radio FM]	Sensitivitas yang dapat digunakan	11.3 dBf (1.0 μ V/75 Ω)
		50 dB Sensitivitas Ketenangan	16.3 dBf (1.8 μ V/75 Ω)
		Selektivitas Chanel Alternatif (400 kHz)	65 dB
		Respon Frekuensi	40 Hz hingga 15 000 Hz
		Pemisah Stereo	35 dB
		Rasio penangkapan	2.0 dB
	[Radio AM]	Sensitivitas	20 μ V
		Selektivitas	35 dB
Bagian Dek Kaset	Bagian Dek Kaset		0.15% (WRMS)
	Waktu Menggulung cepat		190 detik (C-60)
	Respon Frekuensi		50 Hz hingga 14 000 Hz (tape normal)
	Rasio Sinyal ke suara		52 dB
	Pemisah Stereo		40 dB
UMUM	Power yang diperlukan	Tegangan Operasional	DC 14.4 V (diperbolehkan antara 11V hingga 16 V)
		Sistem Grounding	Ground Negatif
	Temperatur kerja yang diperbolehkan		0°C hingga +40°C
	Dimensi (L \times T \times K)	Ukuran pemasangan	182 mm \times 52 mm \times 150 mm
		Ukuran panel	188 mm \times 58 mm \times 11 mm
	Berat		1.3 kg (tidak termasuk aksesoris)

Desain dan spesifikasi dapat berubah tanpa pemberitahuan.

SECTION 1 PRECAUTION

1.1 Safety Precautions



CAUTION Burrs formed during molding may be left over on some parts of the chassis. Therefore, pay attention to such burrs in the case of performing repair of this system.

SECTION 2 SPECIFIC SERVICE INSTRUCTIONS

This service manual does not describe SPECIFIC SERVICE INSTRUCTIONS.

SECTION 3 DISASSEMBLY

3.1 Main body

3.1.1 Removing the front panel assembly (See Fig.1)

- (1) Press the release button and remove the front panel assembly.

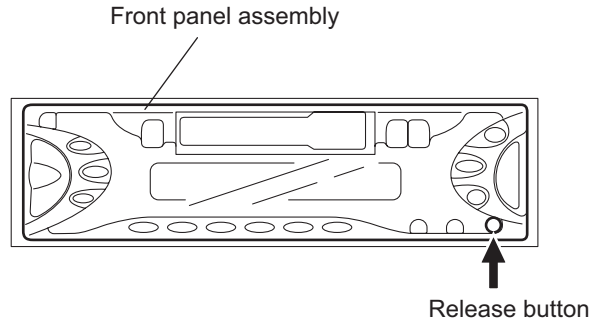

Fig.1

3.1.2 Removing the bottom cover (See Fig.2)

- Prior to performing the following procedure, remove the front panel assembly.
 - (1) Turn the body upside down.
 - (2) Insert a screwdriver under the joints to release the two joints **a** on the left side, the two joints **b** on the right side and the joint **c** on the back of the body, then remove the bottom cover from the body.

CAUTION:

When releasing the joint **c** using a screwdriver, do not damage the board.

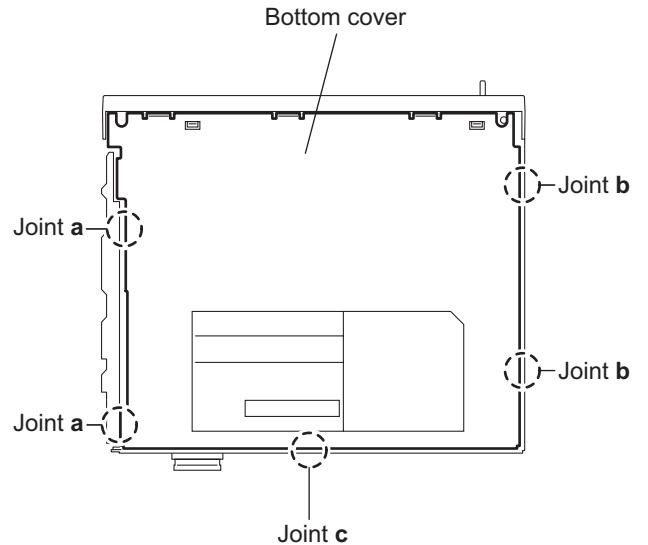

Fig.2

3.1.3 Removing the front chassis (See Fig.3)

- Prior to performing the following procedure, remove the front panel assembly and bottom cover.
 - (1) Remove the screw **A** on each side of the body.
 - (2) Release the two joints **d** and the two joints **e** on the sides, then remove the front chassis toward the front.

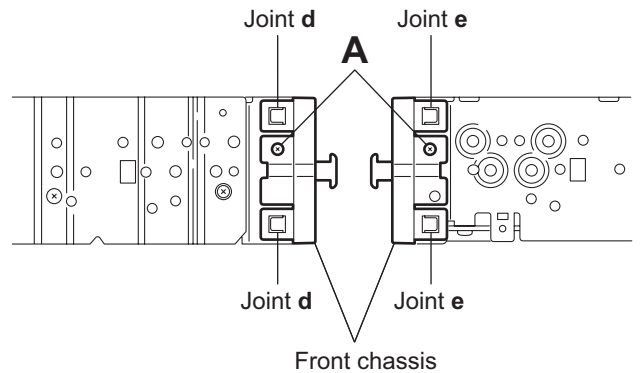

Fig.3

3.1.4 Removing the heat sink (See Fig.4)

- Prior to performing the following procedure, remove the front panel assembly.
 - (1) Remove the screw **B** and two screws **C** attaching the heat sink on the left side of the body, and remove the heat sink.

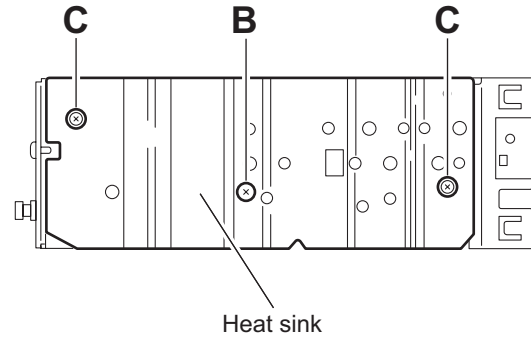

Fig.4

3.1.5 Removing the rear panel (See Fig.5)

- Prior to performing the following procedure, remove the front panel assembly and bottom cover.
 - (1) Remove the two screws **D**, one screw **E** and three screws **F** attaching the rear panel on the back of the body.

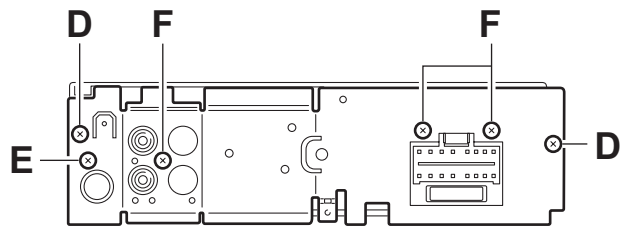

Fig.5

3.1.6 Removing the main board (See Fig.6)

- Prior to performing the following procedure, remove the front panel assembly, bottom cover, front chassis, heat sink and rear panel.
 - (1) Remove the two screws **G** attaching the main board on the top chassis.
 - (2) Disconnect the two connectors [CN901](#) and [CN721](#) on the main board from the cassette mechanism assembly.

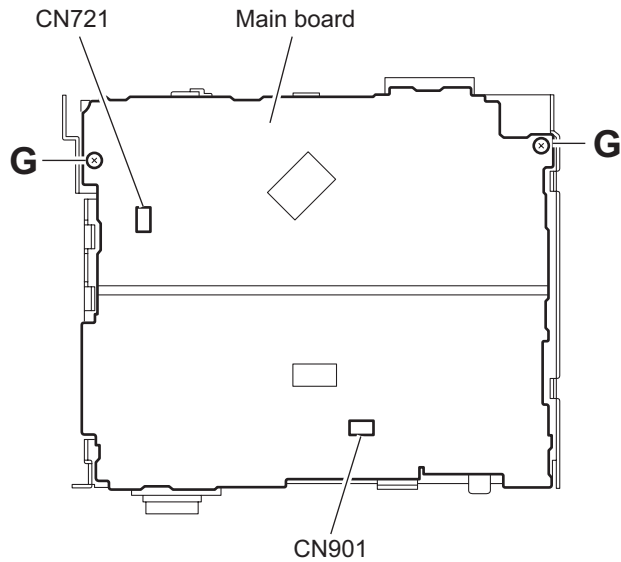

Fig.6

3.1.7 Removing the cassette mechanism assembly (See Fig.7)

- Prior to performing the following procedure, remove the front panel assembly, bottom cover, front chassis, heat sink, rear panel and main board.
- (1) Remove the four screws **H** attaching the cassette mechanism assembly from the top chassis.

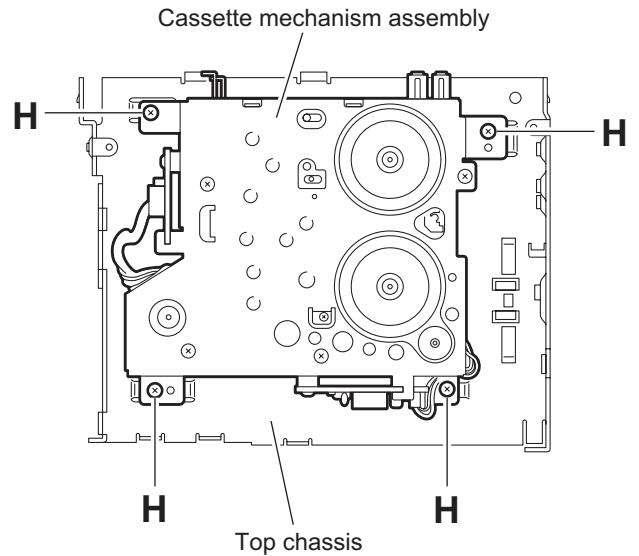

Fig.7

3.1.8 Removing the head amplifier board (See Fig.8)

- Prior to performing the following procedure, remove the front panel assembly, bottom cover, front chassis, heat sink, rear panel, main board and cassette mechanism assembly.
- (1) Disconnect the wire from [CJ901](#) on the head amplifier board.
- (2) Remove the one screw **J** attaching the head amplifier board.
- (3) Move the head amplifier board in the direction of the arrow to release the two joints **f**, the head amplifier board can be removed.

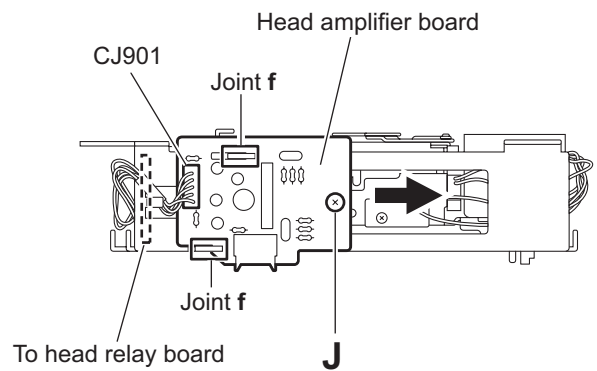

Fig.8

3.1.9 Removing the relay board (See Fig.9)

- Prior to performing the following procedure, remove the front panel assembly, bottom cover, front chassis, heat sink, rear panel, main board and cassette mechanism assembly.
- (1) Disconnect the wire from [CP722](#) on the relay board.
- (2) Remove the one screw **K** attaching the relay board.
- (3) Move the relay board in the direction of the arrow to release the joint **g**, the relay board can be removed.

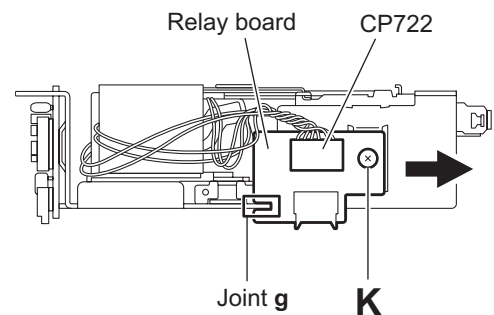

Fig.9

3.1.10 Removing the mecha bracket
(See Fig.10)

- Prior to performing the following procedure, remove the front panel assembly, bottom cover, front chassis, heat sink, rear panel, main board, cassette mechanism assembly, head amplifier board and relay board.
- (1) Remove the four screws **L** attaching the mecha bracket.

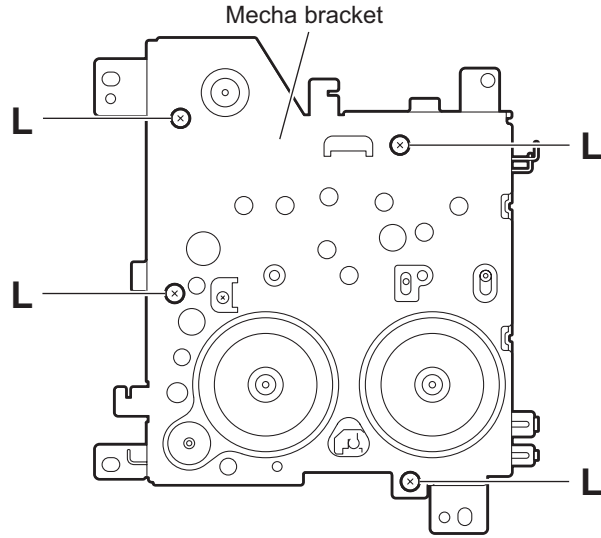

Fig.10

3.1.11 Removing the switch (LCD & key) board
(See Fig.11~13)

- Prior to performing the following procedure, remove the front panel assembly.
- (1) Remove the four screws **M** attaching the rear cover on the back of the front panel assembly.
- (2) Release the eleven joints **h**, the front panel and the rear cover become separate.
- (3) Remove the switch board from the rear cover.

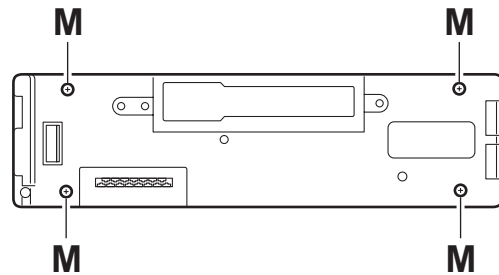

Fig.11

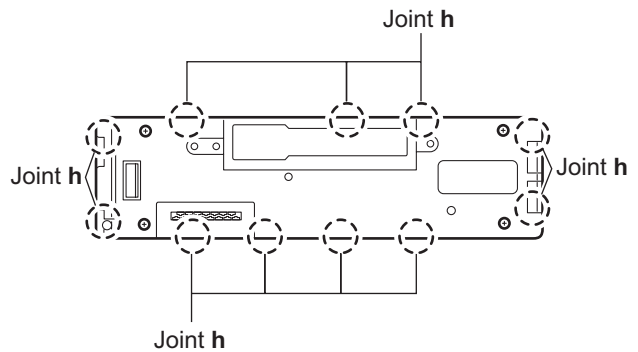

Fig.12

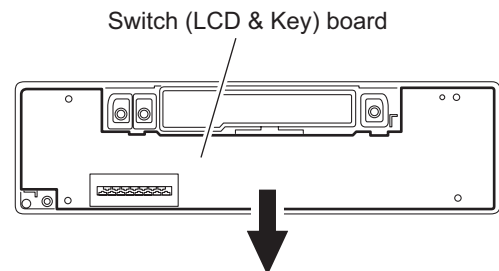

Fig.13

3.2 Cassette mechanism assembly

- Prior to performing the following procedures, remove the head amplifier board, the relay board and the mechanism bracket.

3.2.1 Removing the direction switch board (See Fig.1)

- (1) Unsolder the three wires **a** on the direction switch board.
- (2) Remove the one screw **A** attaching the direction switch board.

3.2.2 Removing the FF / REW lever assembly (See Fig.1)

- (1) Remove the screw **B** attaching the FF / REW lever assembly on the back of the cassette mechanism assembly.
- (2) Remove the screw **C** on the upper side of the FF / REW lever assembly.
- (3) Lift and pull forward the FF / REW lever assembly to disengage the joints **b**, **c**, **d** and **e**.

3.2.3 Reattaching the FF / REW lever assembly (See Fig.1)

- (1) Reattach the FF / REW lever assembly to the joint **c** on the back of the chassis.
- (2) Reattach the pinch-roller shaft **e**, the change lever **d** and the return link **e** to the chassis.

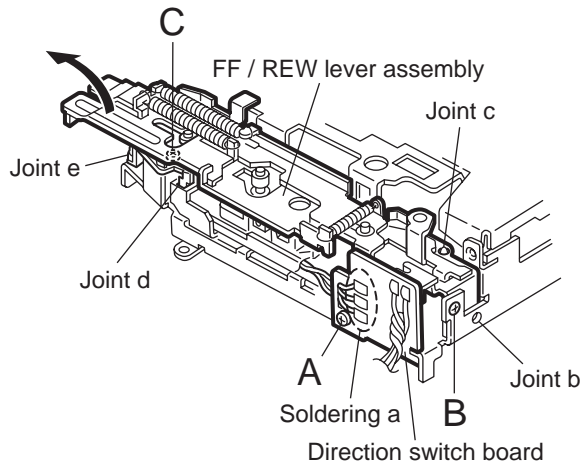

Fig.1

3.2.4 Removing the playback head (See Fig.2)

- Prior to performing the following procedure, remove the direction switch board and the FF / REW lever assembly.
- (1) Remove the screw **D** attaching the playback head.
 - (2) Remove the **C** washer and pull out the FF roller.
 - (3) Remove the **S** support plate, the A arm spring (**a**) and (**b**), the playback head.

ATTENTION:

The A arm spring (**a**) differs from the A arm spring (**b**).

3.2.5 Removing the pinch-roller (R) and (F) assembly (See Fig.2)

- Prior to performing the following procedure, remove the direction switch board and the FF / REW lever assembly.
- (1) Remove the P arm spring (**f**) in the pinch-roller (**F**) assembly from the chassis.
 - (2) Remove the P arm spring (**r**) in the pinch-roller (**R**) assembly from the chassis.
 - (3) Draw out the pinch roller (**F**) and (**R**) assembly from the shaft.

ATTENTION:

The P arm spring (**f**) differs from the P arm spring (**r**).

ATTENTION:

The pinch roller (**F**) assembly differs from the pinch roller (**R**) assembly.

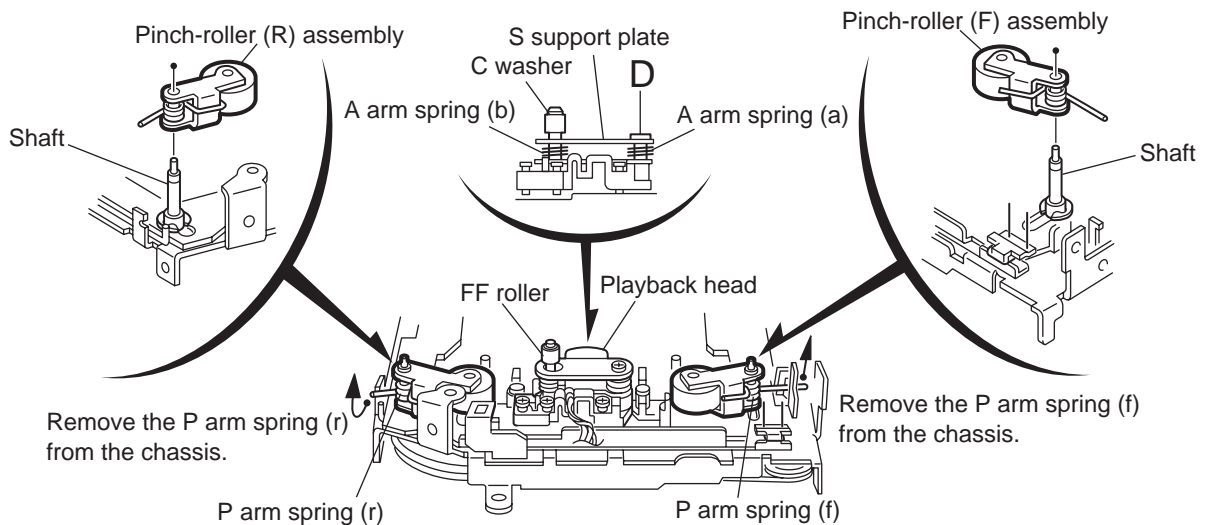
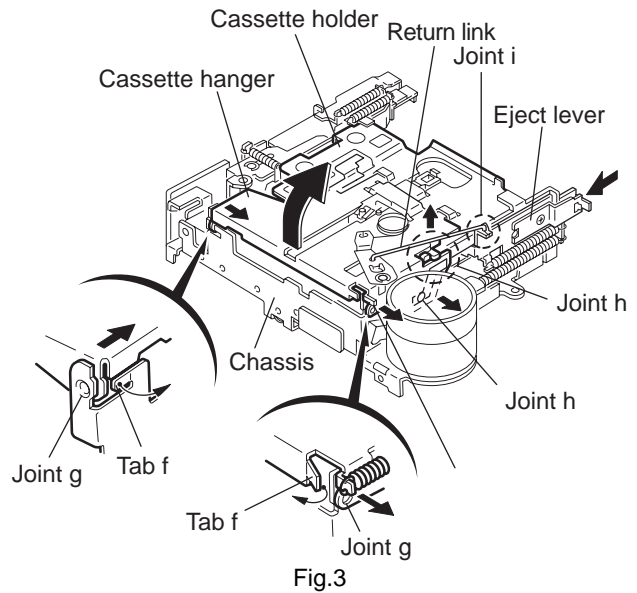

Fig.2

3.2.6 Removing the cassette hanger / cassette holder (See Fig.3)

- Prior to performing the following procedure, remove the FF / REW lever assembly.
 - (1) From the rear of the unit, bend the two tabs **f** outwards and disengage the two joints **g** in the direction of the arrow.
 - (2) Push the eject lever and remove the cassette holder from the playback head. Disengage the two joints **h** of the cassette hanger / cassette holder and the eject lever in the direction of the arrow.
 - (3) Lift the cassette hanger / cassette holder and disengage the joint **i** of the return link and the eject lever.



3.2.7 Removing the reel disc assembly (See Fig.4)

- Prior to performing the following procedure, remove the FF / REW lever assembly and the cassette hanger / cassette holder.
 - (1) Remove the C washer and pull out reel disc assembly.

ATTENTION:

Replace with a new C washer when reattaching.

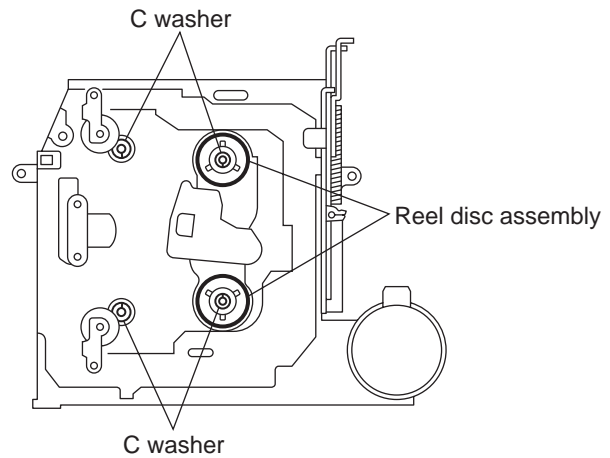

Fig.4

3.2.8 Removing the motor assembly (See Fig.5)

- (1) Unsolder the two wires **j** on the motor assembly.
- (2) Turn over the cassette mechanism assembly and remove the main belt and the sub-belt from the motor pulley.

ATTENTION:

The main belt can now be removed.

- (3) Remove the two screws **G** attaching the motor assembly.

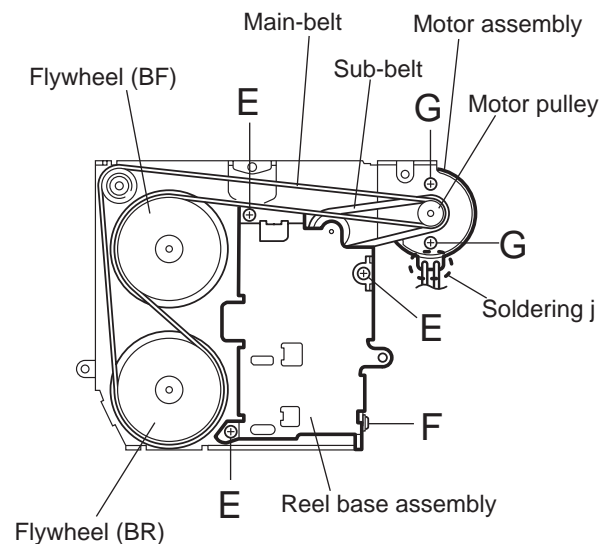

Fig.5

3.2.9 Removing the Flywheel (BF) and (BR) assembly (See Fig.4 and 5)

- Prior to performing the following procedure, remove the cassette hanger / cassette holder.
- (1) From the upper side of the cassette mechanism assembly, remove the C washer from each shaft of the flywheel (BF) and (BR).
- (2) Turn over the cassette mechanism assembly and remove the main belt. Pull out the flywheel (BF) and (BR) downward respectively.

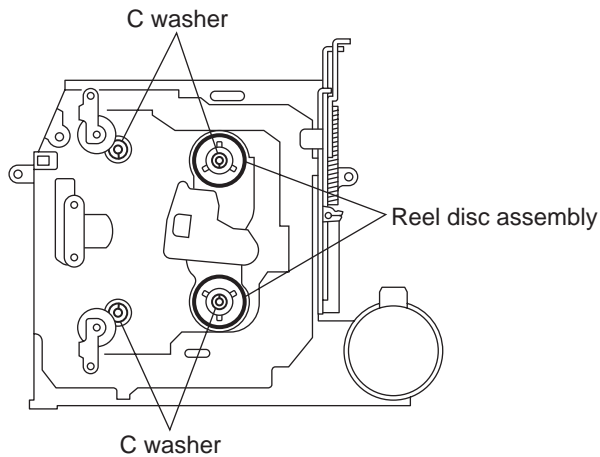

Fig.4

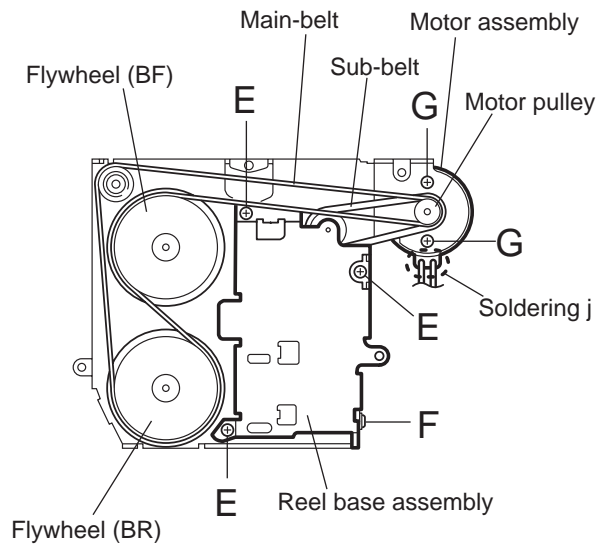

Fig.5

3.2.10 Removing the reel base assembly (See Fig.5 and 6)

- (1) Raise the part **k** of the reel base assembly slightly and remove the selector link (B) on the front side of the cassette mechanism assembly by turning it as shown in Fig.6.
- (2) Remove the three screws **E** and the one screw **F** on the underside of the cassette mechanism assembly.

ATTENTION:

The reel base assembly is not repairable. Handle with care.

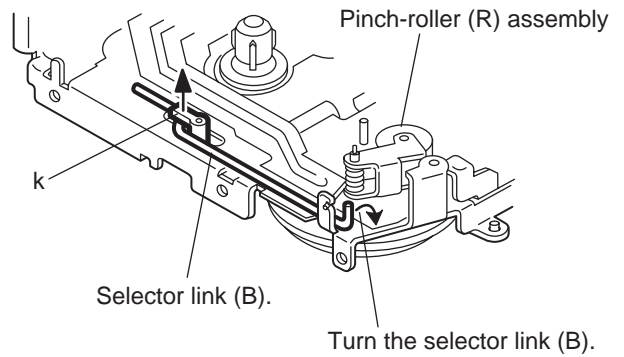

Fig.6

Inside of the reel base assembly

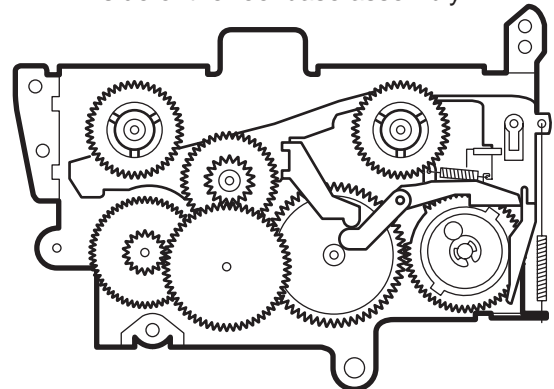
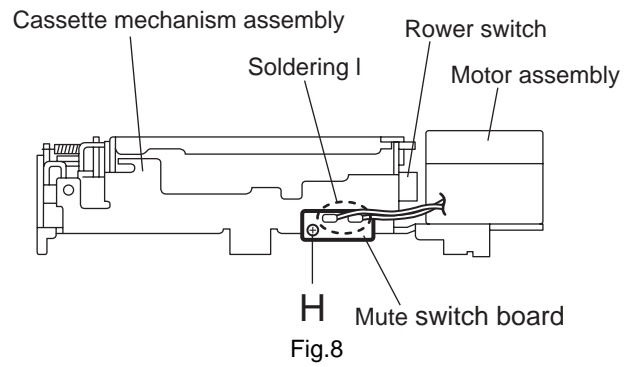

Fig.7

3.2.11 Removing the mute switch board (See Fig.8)

- (1) Unsolder the two wires I on the mute switch board on the back of the cassette mechanism assembly.
- (2) Remove the screw H attaching the mute switch board.



3.2.12 Removing the power switch (See Fig.9)

- Prior to performing the following procedure, remove the motor assembly.
 - (1) Unsolder the two wires m on the power switch on the side of the cassette mechanism assembly.
 - (2) Remove the screw I attaching the power switch.

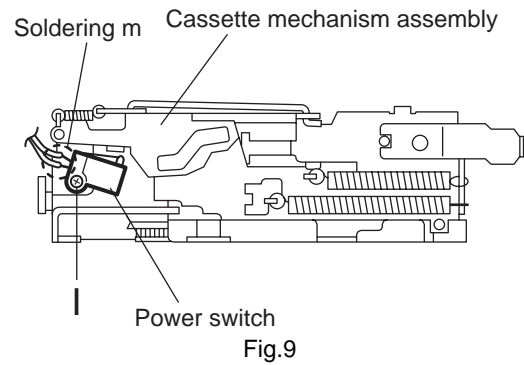

SECTION 4 ADJUSTMENT

4.1 Adjustment method

■ Test instruments required for adjustment

- (1) Digital oscilloscope (100MHz)
- (2) Frequency counter meter
- (3) Electric voltmeter
- (4) Wow & flutter meter
- (5) Test tapes
 - VT724.....For DOLBY level measurement
 - VT739.....For playback frequency measurement
 - VT712.....For wow flutter & tape speed measurement
 - VT703.....For head azimuth measurement
- (6) Torque gauge.....Cassette type for CTG-N

■ Standard volume position

Balance and Bass, Treble volume, Fader : Center (Indication "0")
Loudness, Dolby NR, Sound, Cruise : Off
Volume position is about 2V at speaker output with following conditions, Playback the test tape VT721.

AM mode	999kHz/62dB, INT/400Hz, 30% modulation signal on receiving.
FM mono mode	97.9MHz/66dB, INT/400Hz, 22.5kHz deviation pilot off mono
FM stereo mode	1kHz, 67.5kHz dev. pilot 7.5kHz dev.
Output level	0dB (1 μ V,50 Ω /open terminal)

■ Measuring conditions (Amplifier section)

- Power supply voltage..... DC14.4V (11V to 16V allowance)
- Load impedance..... 4 Ω (4 Ω to 8 Ω allowance)
- Line out level/Impedance.....1.0V/20k load (250 nWb/m)

■ Information for using a car audio service jig

- (1) We're advancing efforts to make our extension cords common for all car audio products.
Please use this type of extension cord as follows.
- (2) As a U-shape type top cover is employed, this type of extension cord is needed to check operation of the mechanism assembly after disassembly.
- (3) Extension cord : EXTKSRT002-6P (6 pin extension cord) For connection between mechanism assembly and main board.
- (4) Check for mechanism driving section such as motor ,etc.

■ Disassembly method

- (1) Remove the front panel assembly.
- (2) Remove the bottom cover.
- (3) Remove the front chassis.
- (4) Remove the heat sink.
- (5) Remove the rear panel
- (6) Remove the main board.
- (7) Reattach the heat sink with the two screws D. (Refer to DISASSEMBLY.)
- (8) Reattach the rear panel with the screw G. (Refer to DISASSEMBLY.)
- (9) Reattach the front chassis assembly with the screw B. (Refer to DISASSEMBLY.).
- (10) Reattach the front panel assembly.
- (11) Confirm that current is being carried by connecting an extension cord jig.

NOTE:

Available to connect to the [CJ701](#) connector when installing the front panel.

CAUTION :

Be sure to attach the heat sink and rear panel on the power amplifier IC and regulator IC of a main board when supplying the power. If voltage is applied without attaching those parts, the power amplifier IC and regulator IC will be destroyed by heat.

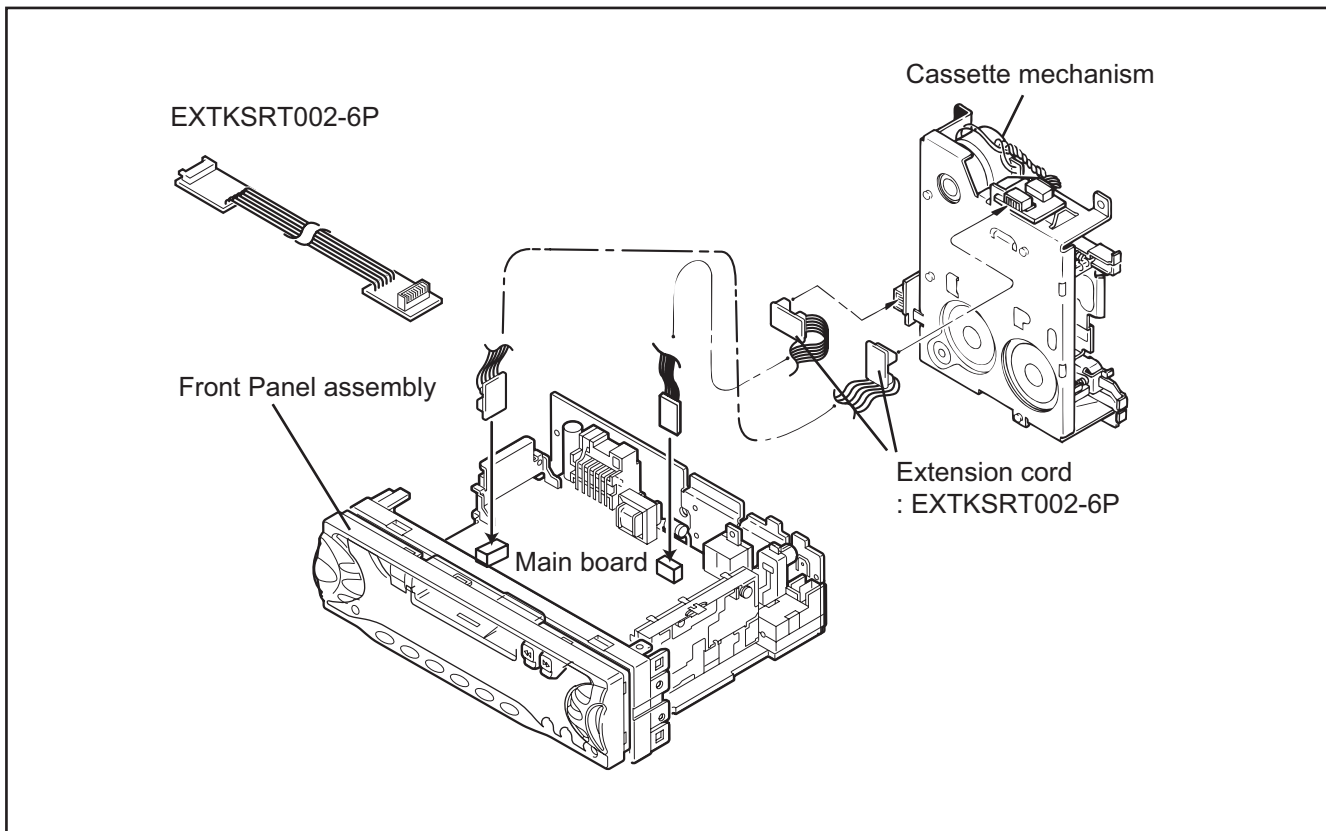

■ Arrangement of adjusting & test points

Cassette mechanism
(Surface)

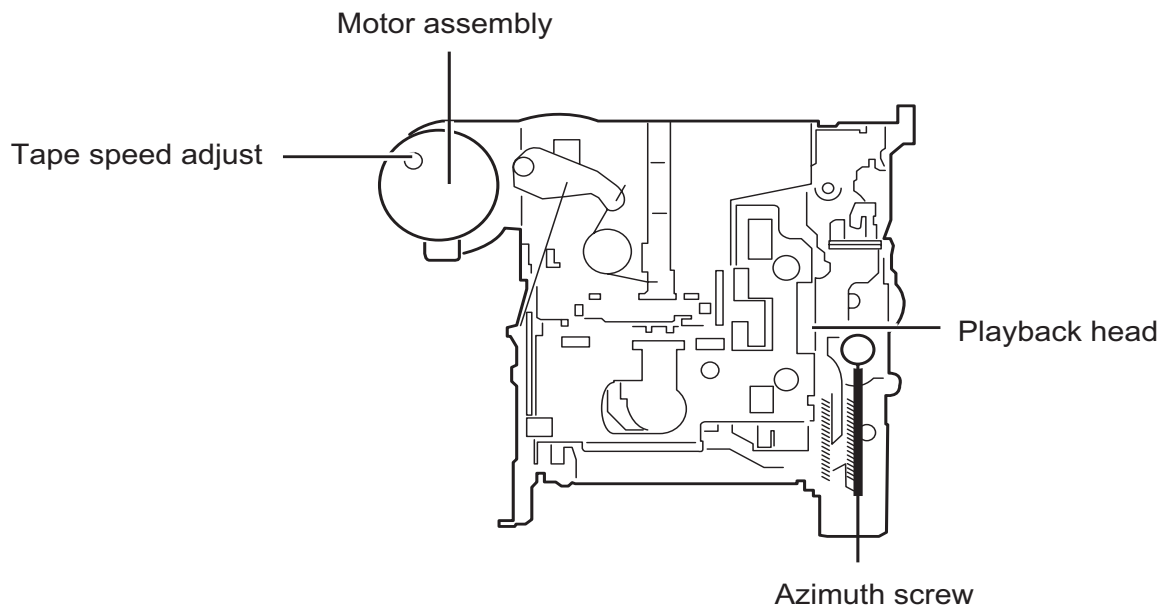

Head section view

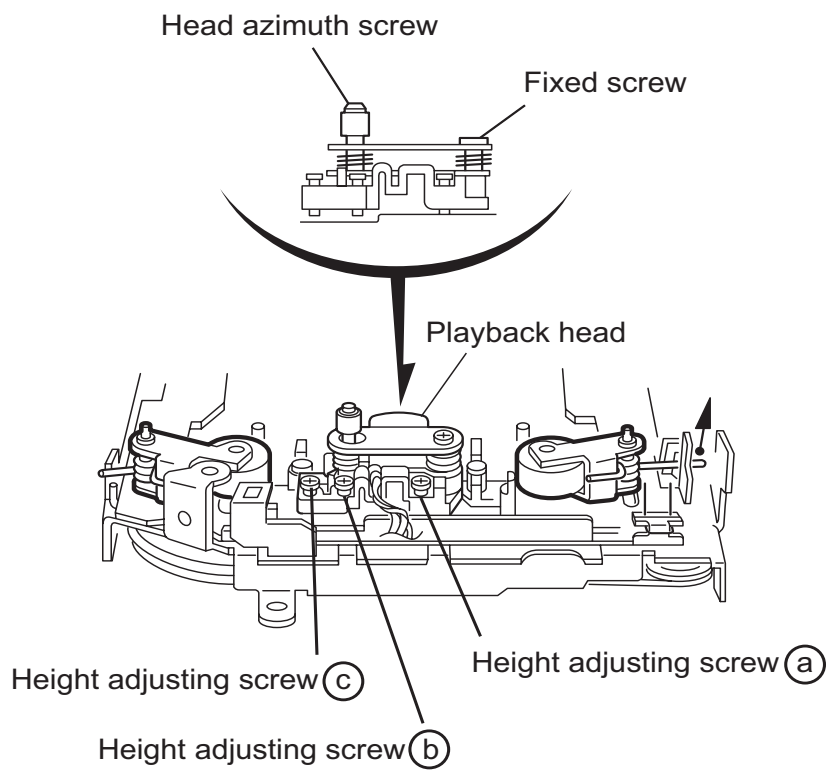

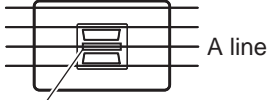
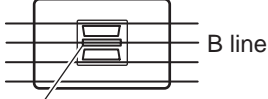
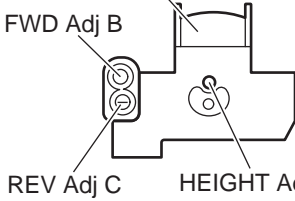
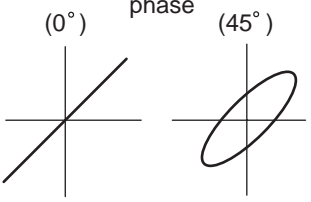
Item	Conditions	Adjustment and Confirmation methods	S.Values	Adjust
1. Head azimuth adjustment	Test tape: SCC-1659 VT703 (10kHz)	<p>◆Head height adjustment</p> <p>Adjust the azimuth directly. When you adjust the height using a mirror tape, remove the cassette housing from the mechanism chassis. After installing the cassette housing, perform the azimuth adjustment.</p> <p>(1) Load the SCC-1659 mirror tape. Adjust with height adjustment screw A and azimuth adjustment screw B so that line A of the mirror tape runs in the center between Lch and Rch in the reverse play mode.</p> <p>(2) After switching from REV to FWD then to REV, check that the head position set in procedure 1 is not changed. (If the position has shifted, adjust again and check.)</p> <p>(3) Adjust with azimuth adjustment screw B so that line B of the mirror tape runs in the center between Lch and Rch in the forward play mode.</p>	 <p>A line</p> <p>Head shield</p> <p>The head is at low position during.</p>  <p>B line</p> <p>Head shield</p> <p>The head is at High position during REV.</p>	
	Test tape: VT724 (1kHz) VT703 (10kHz) VT721 (315Hz)	<p>◆Head azimuth adjustment</p> <p>(1) Load VT724 (1kHz) and play it back in the reverse play mode. Set the Rch output level to max.</p> <p>(2) Load VT703 (10kHz) and play it back in the forward play mode. Adjust the Rch and Lch output levels to max, with azimuth adjustment screw B. In this case, the phase difference should be within 45°.</p> <p>(3) Engage the reverse mode and adjust the output level to max, with azimuth adjustment screw C. (The phase difference should be 45° or more.)</p> <p>(4) When switching between forward and reverse modes, the difference between channels should be within 3dB. (Between FWD L and R, REV L and R.)</p> <p>(5) When VT721 (315Hz) is played back, the level difference between channels should be within 1.5dB.</p>	<p>Output level: Maximum</p>  <p>PBHead</p> <p>FWD Adj B</p> <p>REV Adj C</p> <p>HEIGHT Adj A</p> <p>phase</p>  <p>(0°)</p> <p>(45°)</p>	
2. Tape speed and wow flutter confirmation	Test tape: VT712 (3kHz)	<p>(1) Check to see if the reading of the F, counter / wow flutter meter is within 3015Hz to 3045Hz (FWD/REV), and less than 0.35% (JIS RMS).</p> <p>(2) In case of out of specification, adjust the motor with a built-in volume resistor.</p>	<p>Tape speed: 3015Hz to 3045Hz</p> <p>Wow flutter: less than 0.35%</p>	Built-in volume resistor
3. Play back frequency response confirmation	Test tape: VT724 (1kHz) VT739 (63Hz / 1kHz / 10kHz)	<p>(1) Play test tape VT724, and set the volume position at 2V.</p> <p>(2) Play test tape VT739 and confirm. 1kHz / 10kHz: -1 ±3dB, 1kHz / 63Hz: 0 ±3dB,</p> <p>(3) When 10kHz is out of specification, it will be necessary to read adjust the azimuth.</p>	<p>Speaker out</p> <p>1kHz / 63Hz: 0 ±3dB</p> <p>1kHz / 10kHz: -1 ±3dB</p>	

The tuner section is of an adjustment-free design. In case the tuner is in trouble, replace the tuner pack.

SECTION 5 TROUBLE SHOOTING

This service manual does not describe TROUBLE SHOOTING.



JVC

VICTOR COMPANY OF JAPAN, LIMITED

AV & MULTIMEDIA COMPANY MOBILE ENTERTAINMENT CATEGORY 10-1,1chome,Ohwatari-machi,Maebashi-city,371-8543,Japan

(No.MA007)



Printed in Japan
WPC

JVC

SCHEMATIC DIAGRAMS

RADIO KASET

KS-F171G

CD-ROM No.SML200309

Area Suffix

UN -----Asean

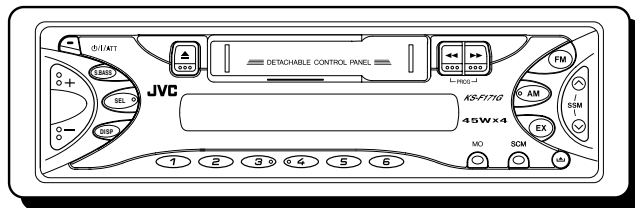
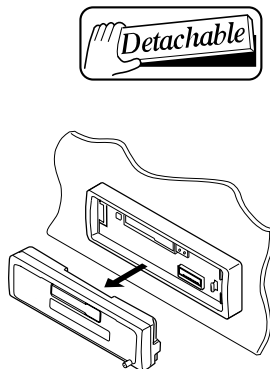

Contents

Block diagram	2-1
Standard schematic diagrams	2-2
Printed circuit boards	2-5,6

Safety precaution

 **CAUTION** Burrs formed during molding may be left over on some parts of the chassis. Therefore, pay attention to such burrs in the case of performing repair of this system.

Block diagram

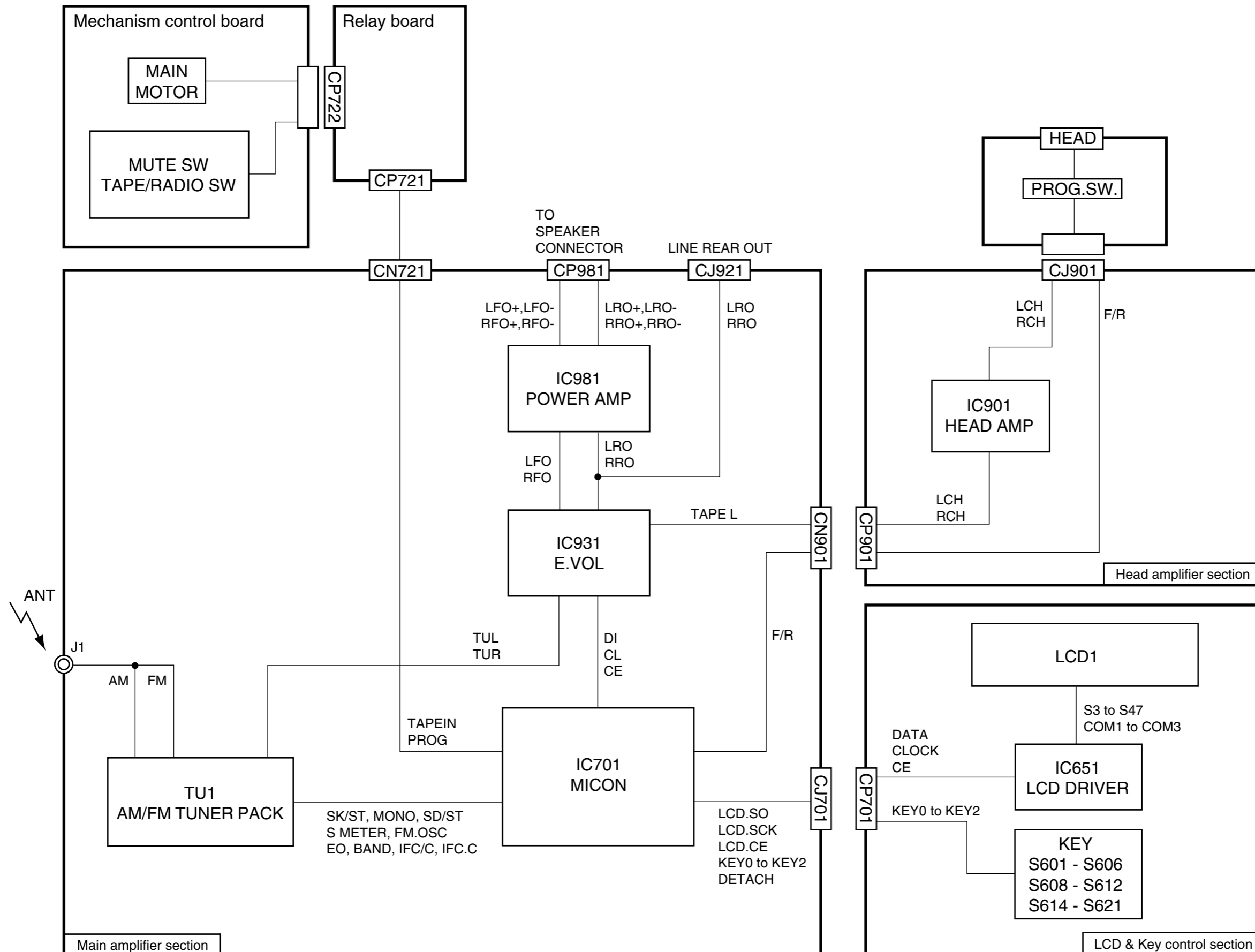

Standard schematic diagrams

■ Main amplifier section

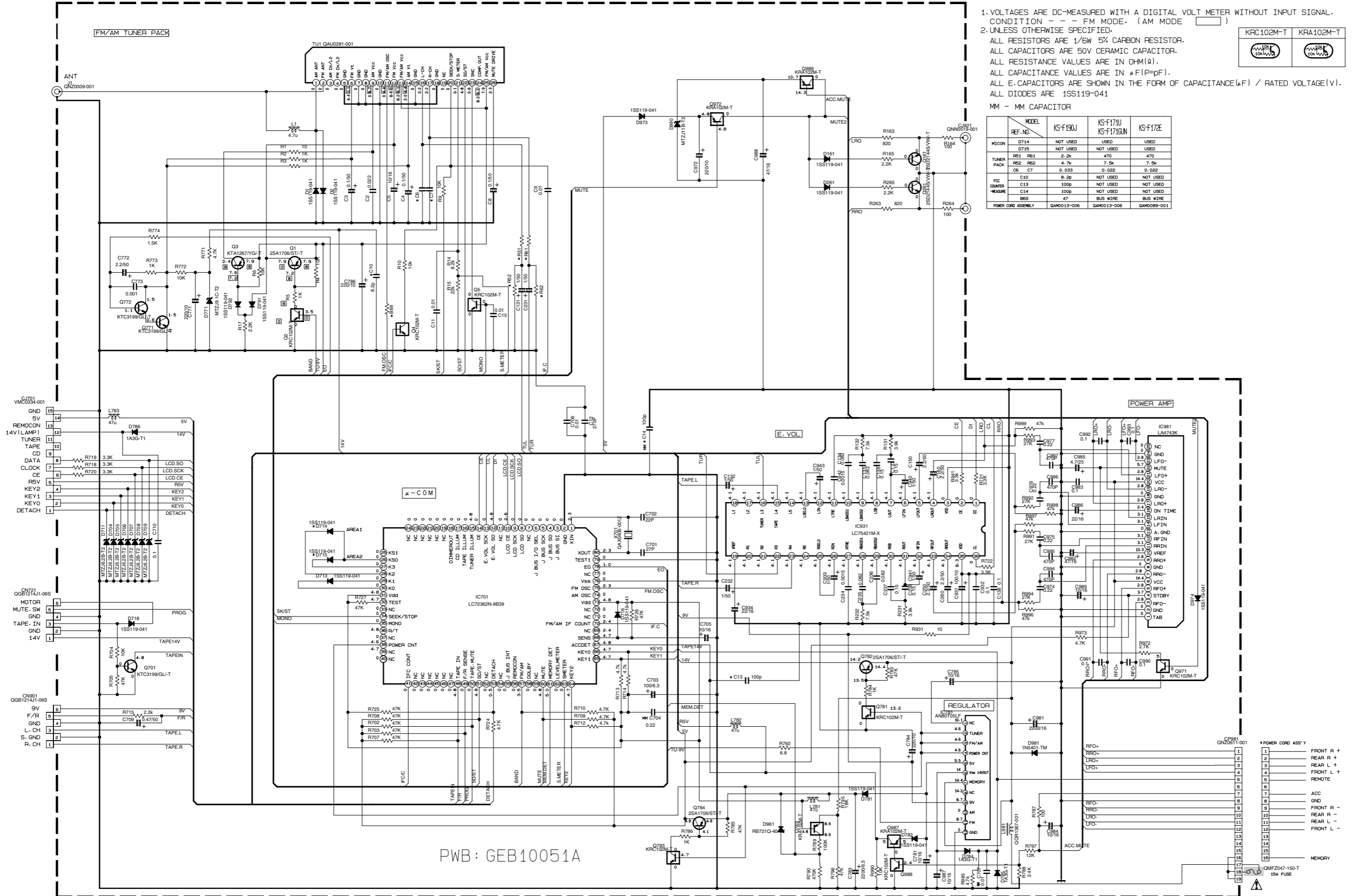

NOTES

- VOLTAGES ARE DC-MEASURED WITH A DIGITAL VOLT METER WITHOUT INPUT SIGNAL. CONDITION - - - FM MODE. (AM MODE)
- UNLESS OTHERWISE SPECIFIED, ALL RESISTORS ARE 1/6W 5% CARBON RESISTOR. ALL CAPACITORS ARE 50V CERAMIC CAPACITOR. ALL RESISTANCE VALUES ARE IN OHM(Ω). ALL CAPACITANCE VALUES ARE IN μF(P=pF). ALL E-CAPACITORS ARE SHOWN IN THE FORM OF CAPACITANCE(μF) / RATED VOLTAGE(V). ALL DIODES ARE 1SS119-041

MM - MM CAPACITOR

MODEL	KS-F190J	KS-F171U KS-F1716UN	KS-F172E
MICRON	D714	NOT USED	USED
	D715	NOT USED	USED
TUNER PACK	R51 R61	2.2K	470
	R52 R62	4.7K	7.5K
	C6 C7	0.033	0.022
FC	C10	8.2p	NOT USED
COMPAR	C13	100p	NOT USED
HEADFE	C14	100p	NOT USED
	B69	47	BLU WIRE
POWER CORD ASSEMBLY	GAM0013-006	GAM0013-006	GAM0089-001

PWB: GEB10051A

■ LCD & Key control section

	KS-F190J	KS-F172E	KS-F171U KS-F171GUN
R635	820	820	820
R636	1k	820	820
R637	1k	1.5k	1.5k
R638	820	820	820
R639	820	820	820
R640	1.2k	1.5k	1k
R641	1.2k	1.5k	1.8k
R642	820	820	820
R643	820	820	820
R644	620	560	560
R645	620	620	620
R646	820	820	820
R647	820	820	820
R648	1k	820	820
R649	1k	1.5k	1.5k

NOTES
 1. VOLTAGES ARE DC-MEASURED WITH A DIGITAL VOLT METER WITHOUT INPUT SIGNAL.
 CONDITION --- FM MODE
 2. UNLESS OTHERWISE SPECIFIED,
 ALL RESISTORS ARE 1/4W 5% CARBON RESISTOR OR 1/4W 1/10W 5% METAL GLAZE RESISTOR.
 ALL CAPACITORS ARE 50V CERAMIC CAPACITOR.
 ALL RESISTANCE VALUES ARE IN OHM (Ω).
 ALL CAPACITANCE VALUES ARE IN μF (μF).
 ALL E-CAPACITORS ARE SHOWN IN THE FORM OF CAPACITANCE(μF) / RATED VOLTAGE(V).

	D601	D60B	OTHER	PL601 PL603
KS-F190J	SML-310LT/MN/-X	LT1F67AF-W	SML-310VT/JK/-X	QLL0151-001
KS-F171U KS-F171GUN	SML-310LT/MN/-X	LNJ308GB1/1-3/X	LNJ308GB1/1-3/X	QLL0151-001
KS-F172E	SML-310LT/MN/-X	SML-310VT/JK/-X	LNJ308GB1/1-3/X	QLL0152-001

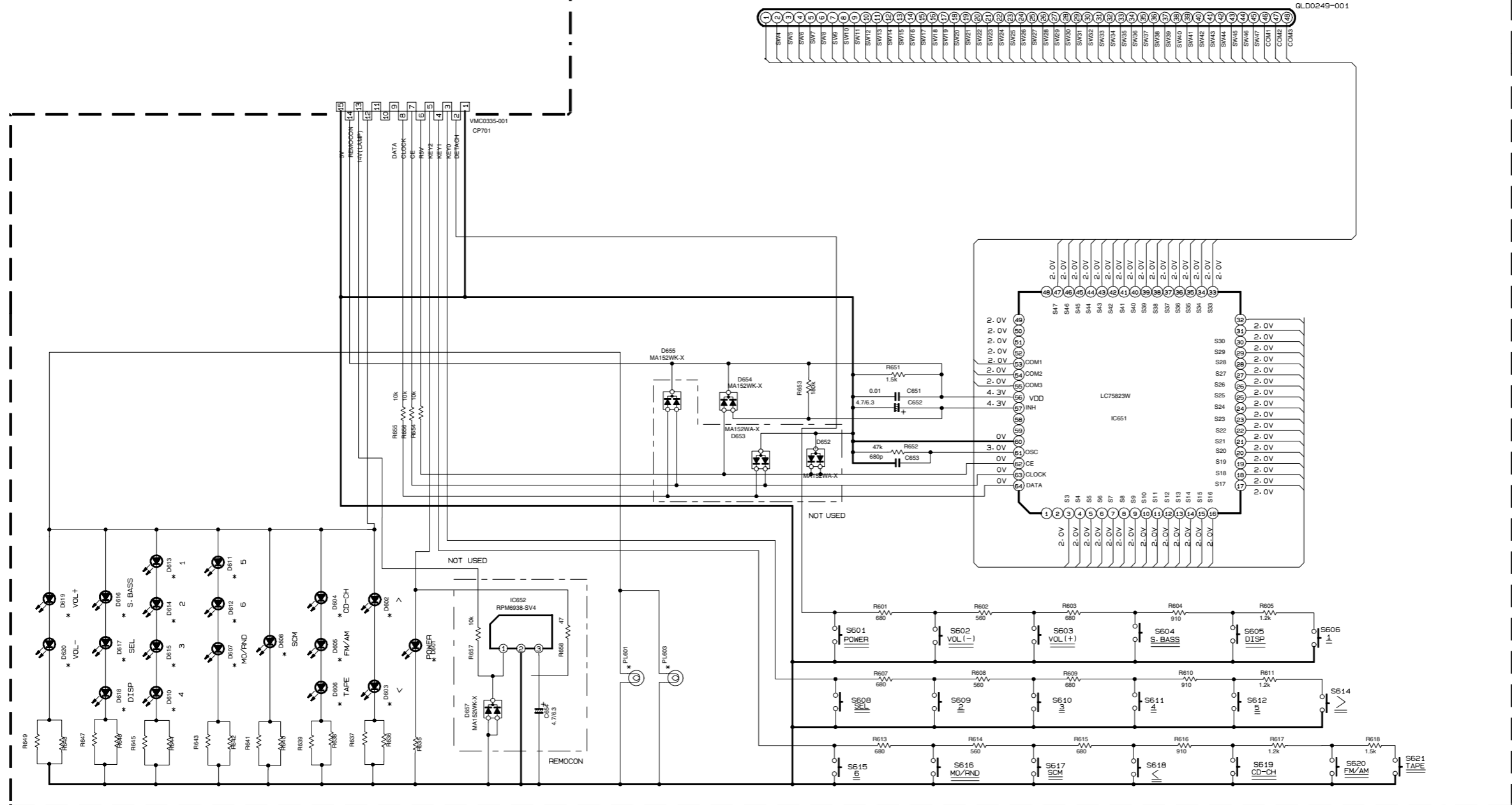
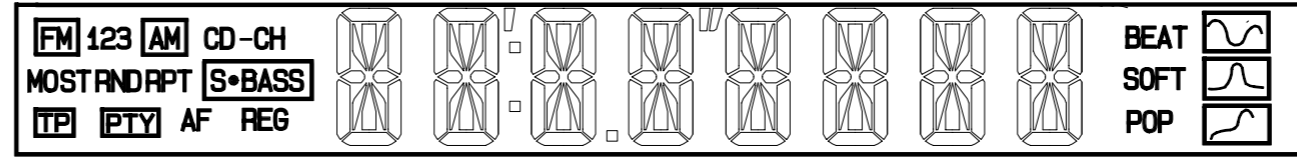

SWITCH PWB : GEB10065A

■ Head amplifier section

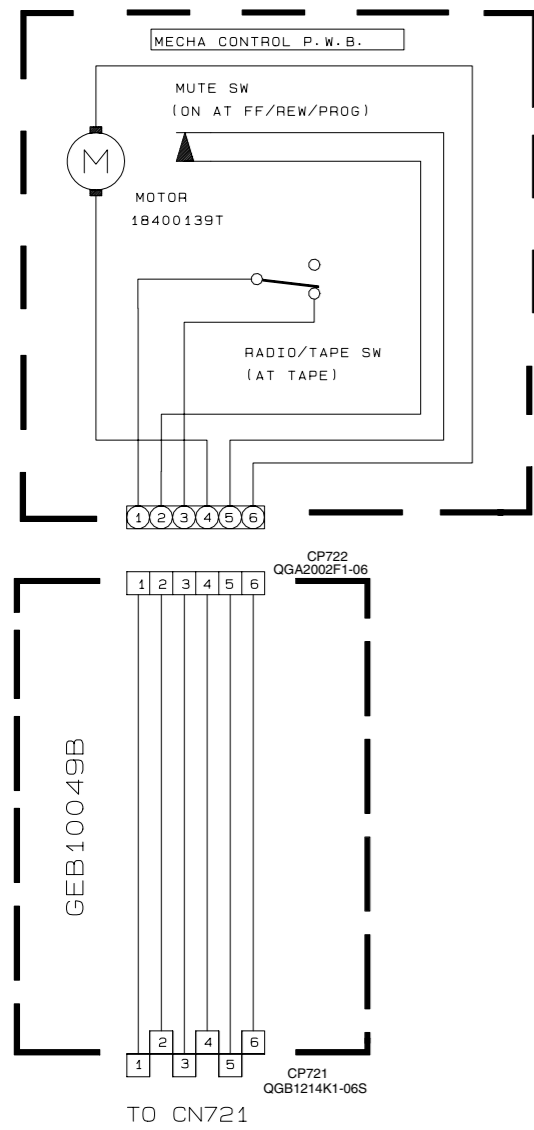

NOTES

1. VOLTAGES ARE DC-MEASURED WITH A DIGITAL VOLT METER WITHOUT INPUT SIGNAL.
CONDITION---FM MODE
2. UNLESS OTHERWISE SPECIFIED.
ALL RESISTORS ARE 1/4W 5% CARBON RESISTOR OR 1/4W.1/10W 5% METAL GLAZE RESISTOR.
ALL CAPACITORS ARE 50V CERAMIC CAPACITOR.
ALL RESISTANCE VALUES ARE IN OHM(Ω).
ALL CAPACITANCE VALUES ARE IN uF(P=pF).
ALL E. CAPACITORS ARE SHOW IN THE FORM OF CAPACITANCE (uF)/RATED VOLTAGE(V).

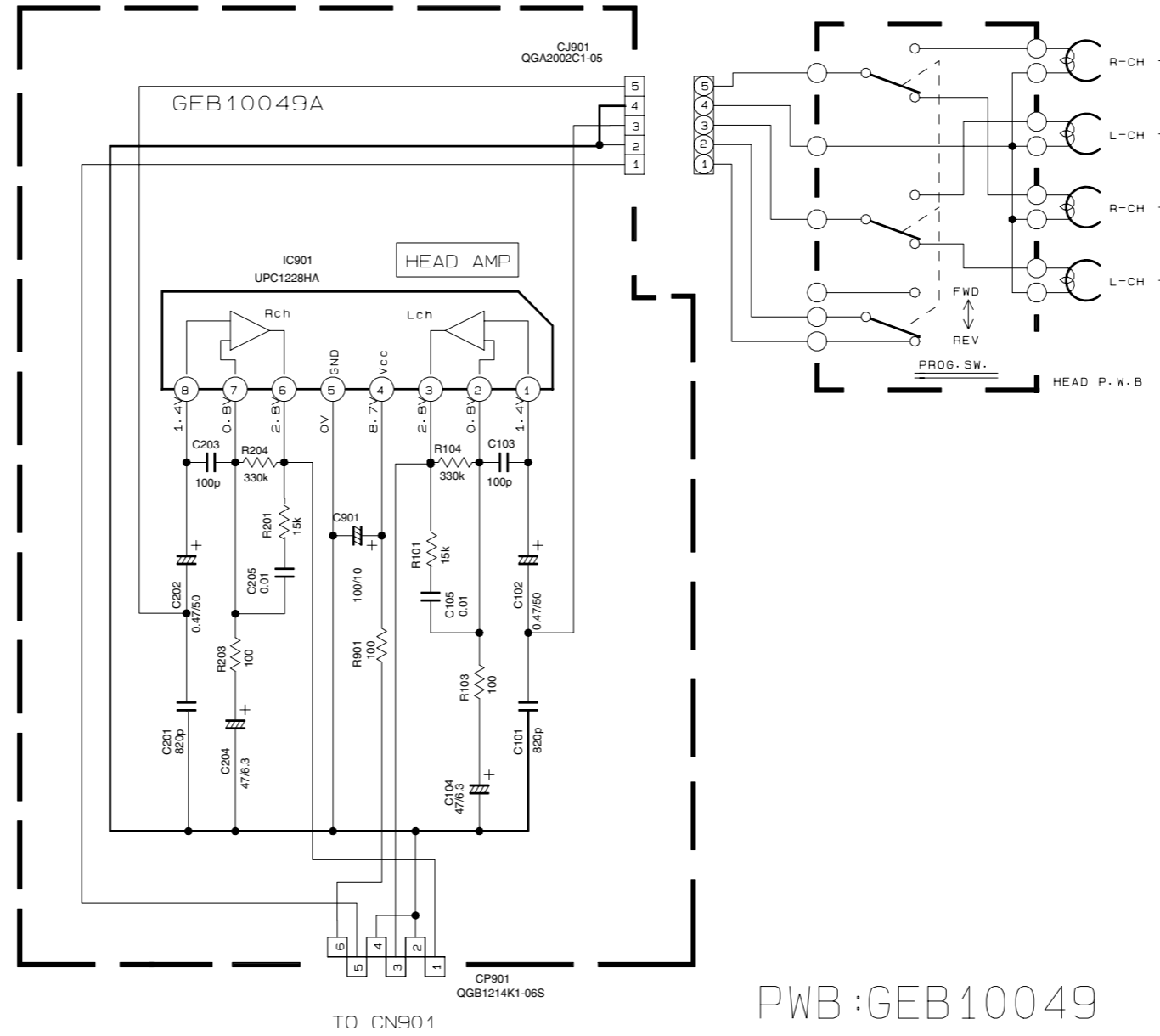

PWB:GEB10049

Printed circuit boards

■ Main board

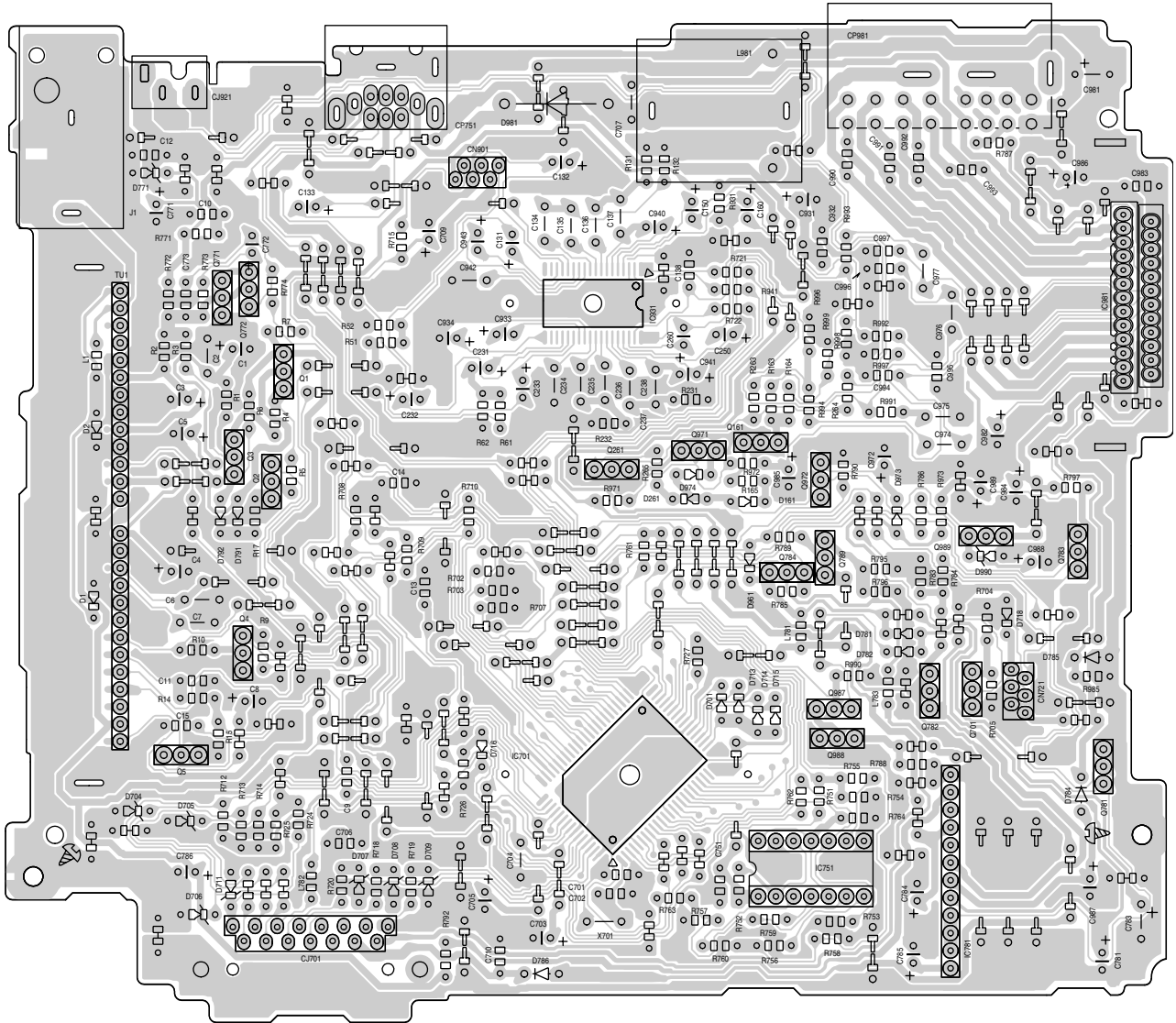

■ Front board

Forward side

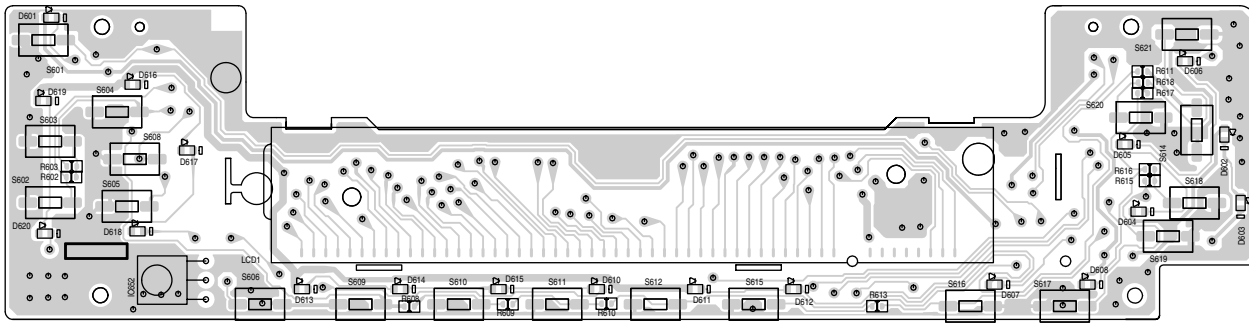

Reverse side

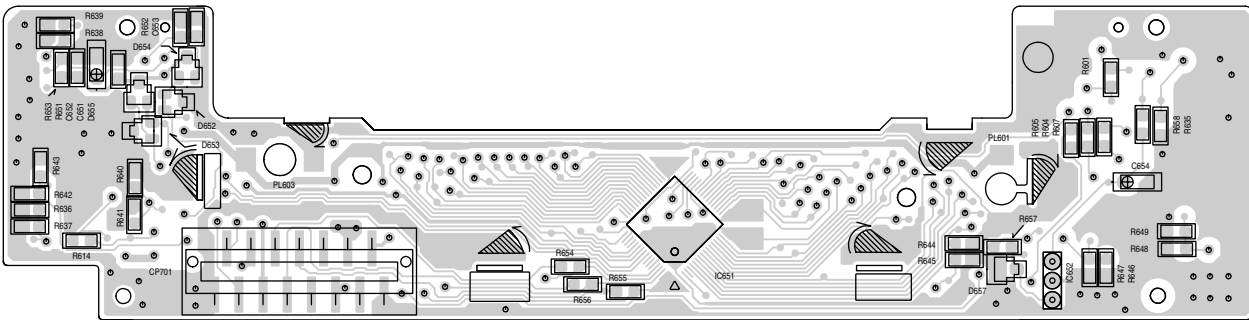

■ Mecha board

(Relay board)

(Head amplifier board)

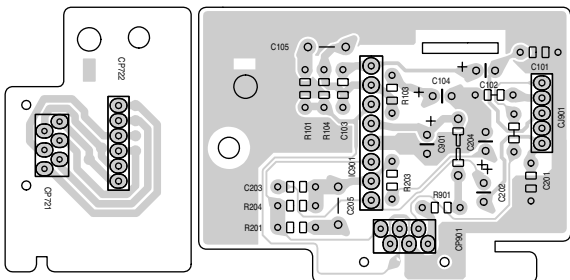

< MEMO >

JVC

VICTOR COMPANY OF JAPAN, LIMITED

AV & MULTIMEDIA COMPANY MOBILE ENTERTAINMENT CATEGORY 10-1,1chome,Ohwatari-machi,Maebashi-city,371-8543,Japan

(No.MA007SCH)



Printed in Japan
WPC

PARTS LIST

[KS-F171G]

* All printed circuit boards and its assemblies are not available as service parts.

Area suffix

UN -----Asean

- Contents -

Exploded view of general assembly and parts list (Block No.M1)	3-2
Cassette mechanism assembly and parts list (Block No.MP)	3-4
Electrical parts list (Block No.01~03)	3-8
Packing materials and accessories parts list (Block No.M3)	3-12

Exploded view of general assembly and parts list

Block No. M 1 M M

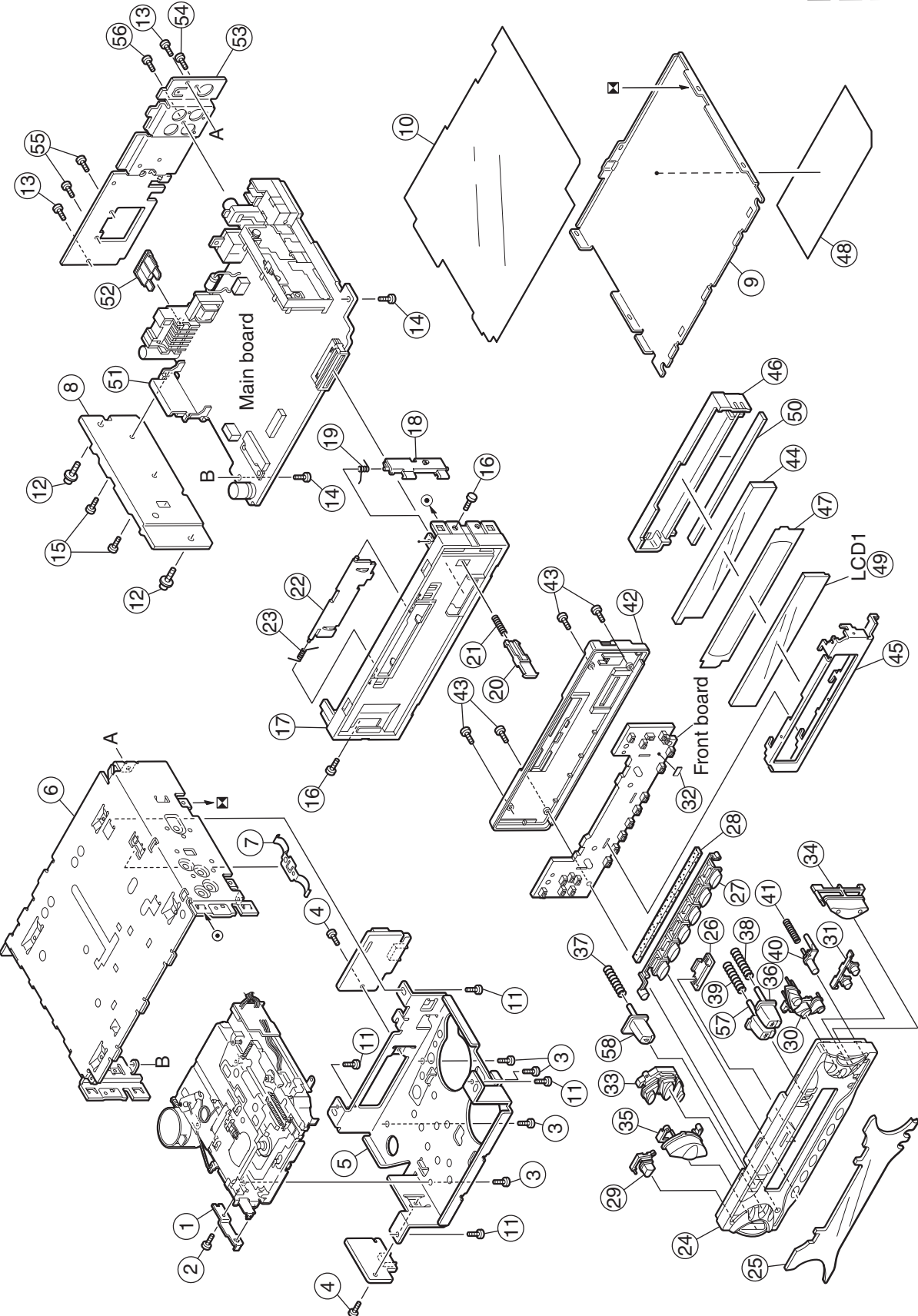

General Assembly

Block No. [M][1][M][M]

Symbol No.	Part No.	Part Name	Description	Local
1	VKL7821-001	EJECT LEVER		
2	QYSPST2625Z	SCREW	2.6mm x 2.5mm	
3	QYSDSP2604Z	SCREW	2.6mm x 4mm(x4)	
4	QYSDST2605Z	SCREW	2.6mm x 5mm(x2)	
5	GE20134-001A	MECHA BKT		
6	GE10043-011A	TOP CHASIS		
7	GE40135-001A	EARTH PLATE		
8	GE30938-003A	SIDE PANEL		
9	GE30393-001A	BOTTOM COVER		
10	FSMA3004-203	INSULATOR		
11	QYSDST2604Z	SCREW	2.6mm x 4mm(x4)	
12	FSKZ4005-001	SCREW	(x2)	
13	QYSDST2604Z	SCREW	2.6mm x 4mm(x2)	
14	QYSDST2606Z	SCREW	2.6mm x 6mm(x2)	
15	QYSDST2610Z	SCREW	2.6mm x 10mm	
16	QYSDST2004M	MINI SCREW	2mm x 4mm(x2)	
17	GE10053-001A	FRONT CHASSIS		
18	GE30583-001A	LOCK LEVER		
19	FSKW4005-003	TORSION SPRING		
20	FSXP3026-002	RLS KNOB		
21	FSKW3002-004	COMP.SPRING		
22	FSJC3014-002	CASSETTE LID		
23	VKW4947-002	DOOR SPRING		
24	GE10051-004A	FRONT PANEL		
25	GE30584-018A	FINDER ASSY		
26	FSJK3014-001	LIGHT LENS		
27	GE20119-001A	PRESET BUTTON		
28	FSYH4036-077	SHEET		
29	GE30304-001A	POWER BUTTON		
30	GE20131-023A	D.FUNC BUTTON		
31	GE30307-001A	SND.FUNC.BUTTON		
32	FSYH4036-032	SHEET		
33	GE20130-033A	PUSH BUTTON		
34	GE20120-002A	UP/DOWN BUTTON		
35	GE20118-002A	+/- BUTTON		
36	FSXP3066-001	FF BUTTON		
37	FSKW3002-003	COMP.SPRING		
38	FSKW3002-003	COMP.SPRING		
39	FSKW3002-003	COMP.SPRING		
40	GE30306-001A	DETACH BUTTON		
41	FSKW3002-012	COMP.SPRING		
42	GE10052-001A	REAR COVER		
43	VKZ4777-001	MINI SCREW	(x4)	
44	FSJK3033-001	LCD LENS		
45	GE30309-002A	LCD CASE		
46	FSKS3020-003	LENS CASE		
47	FSYH4075-003	LIGHTING SHEET		
48	GE31002-001A	NAME PLATE		
49	QLD0249-001	LCD MODULE		
50	QNZ0440-001	LCD CONNECTOR		
51	GE40172-002A	IC BRACKET		
△ 52	QMFZ047-150-T	FUSE	15A	
53	GE30382-015A	REAR BRACKET		
54	QYSDST2606Z	SCREW	2.6mm x 6mm	
55	QYSDSF2606Z	SCREW	2.6mm x 6mm(x2)	
56	QYSDSF2606Z	SCREW	2.6mm x 6mm	
57	FSXP3067-001	REW BUTTON		
58	FSXP3065-001	EJECT BUTTON		

Cassette mechanism assembly and parts list

CDS-363SJ1

Block No. M P M M

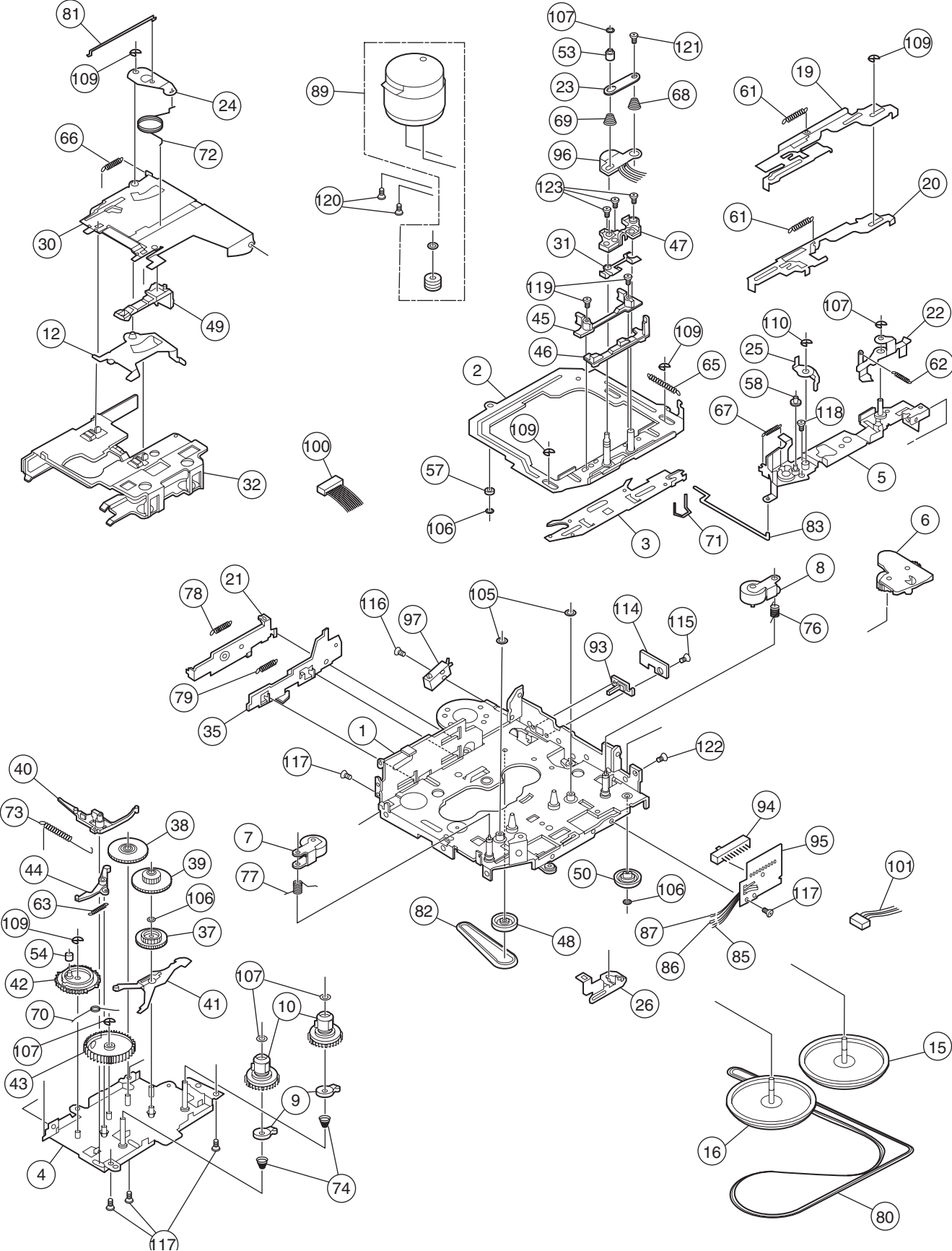

Cassette mechanism

Block No. [M][P][M][M]

△ Symbol No.	Part No.	Part Name	Description	Local
1	X-0363-1001S	MAIN CHASSIS AS		
2	X-0363-1002S	HEAD PLATE ASSY		
3	X-0363-1004S	FR CONV ARM (A)		
4	X-0363-6001S	REEL BASE ASSY		
5	X-0363-6007S	LEVER BRKT ASSY		
6	X-0363-6003S	TU GEAR ARM ASS		
7	X-0363-6004S	PINCH ARM(R) AS		
8	X-0363-6005S	PINCH ARM(F) AS		
9	X-0363-6006S	DETECTOR CAM AS	(x2)	
10	X-0363-2005S	REEL SPINDLE AS	(x2)	
12	X-0036-1019S	EJ.CAM LOCK ASY		
15	1-0363-6010S	FLYWHEEL ASSY F		
16	1-0363-6011S	FLYWHEEL ASSY R		
19	1-0036-1065S	FF LEVER(JVC)		
20	1-0036-1066S	REW LEVER(JVC)		
21	1-0036-1007S	EJECT LEVER		
22	1-0036-1013S	LOCK ARM		
23	1-0036-1015S	SPG SUPPORT PLT		
24	1-0036-1018S	CENTER PLATE		
25	1-0036-1023S	CHANGE LEVER(B)		
26	1-0036-1026S	FR ARM(B)		
30	1-0138-1002S	CASSETTE HANGER		
31	1-0138-1006S	ADJUSTER SHIN(X		
32	1-0138-1010S	CASSETTE HOLDER		
35	1-0363-1003S	EJECT CAM		
37	1-0036-2001S	IDLE GEAR		
38	1-0036-2003S	REDUCT.GEAR(B)		
39	1-0036-2004S	REDUCT.GEAR(A)		
40	1-0036-2007-5S	RATCHET		
41	1-0036-2009S	SENSOR ARM		
42	1-0036-2010S	SELECTOR GEAR		
43	1-0036-2014S	DETECTOR GEAR		
44	1-0038-2014S	GEAR LOCK ARM		
45	1-0038-2018S	TAPE GUIDE		
46	1-0363-2006S	ADJUSTER LINK B		
47	1-0138-2005-3S	ADJUSTER ARM(B)		
48	1-0036-2005S	PULLEY GEAR		
49	1-0032-2007S	TAPE HOOKER		
50	1-0058-2021-5S	IDLE PULLEY(A)		
53	1-0363-3018S	FF ROLLER		
54	1-0036-3018S	COLLER		
57	1-0363-3007S	HP ROLLER(A)		
58	1-0363-3011S	PROGRAM ROLLER		
61	1-0036-4001S	FF/REW LEVER SP		
62	1-0036-4002S	LOCK LEVER SPG		
63	1-0036-4003S	GEAR LOCK ARM S		
65	1-0036-4006S	HEAD PLATE SPG		
66	1-0036-4007S	EJ.CAM LOCK SPG		
67	1-0036-4008S	PROGRAM ARM SPG		
68	1-0036-4010S	ADJUST ARM SP(A		
69	1-0036-4011S	ADJUST ARM SP(B		
70	1-0036-4015S	DASH SPG		
71	1-0036-4017S	CHANGING ARM SP		
72	1-0036-4023S	CENTER PLT SP(B		
73	1-0038-4014S	RATCHET SPG		
74	1-0138-4001S	BACK TEMSION SP		
76	1-0363-4003S	PINCH ARM SPG F		
77	1-0363-4004S	PINCH ARM SPG R		
78	1-0363-4005S	EJECT LEVER SPG		
79	1-0036-4005S	EJECT CAM SPG		
80	1-0036-5020S	MAIN BELT(AL)		
81	1-0363-5007S	RETURN LINK		
82	1-0036-5001S	SUB BELT		
83	1-0363-5003S	SELECTOR LINK B		
85	1-0036-7002S	WIRE(A)		
86	1-0036-7003S	WIRE(B)		
87	1-0036-7073S	WIRE(AL)		
89	X-0363-7006S	MOTOR ASSY		
93	1-0363-7001S	MUTE SW		
94	1-0363-7002S	SLIDE SW		
95	1-0363-7008S	SLIDE SW PWB		
96	1-0036-7016S	HEAD		
97	1-0363-7005S	POWER SW		

△ Symbol No.	Part No.	Part Name	Description	Local
100	1-0036-7089S	6P WIRE ASY(JVC		
101	1-0036-7088S	5P WIRE ASY(JVC		
105	2-1816-0032-E8S	MYLAR WASHER(S)	(x2)	
106	2-1812-0030-D2S	PSW-S	(x3)	
107	1-0036-5024S	PSW(REEL)	(x5)	
109	2-1712-0050-16S	E RING	(x5)	
110	2-1712-5060-16S	E RING		
114	1-0363-7015S	MUTE SW PWB		
115	2-1331-7040-C2S	SCREW S		
116	2-1331-7060-C2S	SCREW S		
117	2-1382-0030-C2S	SCREW B	(x5)	
118	2-1332-0040-C1S	SCREW S		
119	2-1032-0070-C2S	SCREW	(x2)	
120	2-1032-0025-C2S	SCREW	(x2)	
121	2-1012-0040-C2S	SCREW		
122	2-1012-0030-F2S	SCREW		
123	1-0138-5002S	AZIMUTH SCREW	(x3)	

Grease point 1/2

- Grease
- FL-942
 - SW-902
 - ▲ SW-522B
 - ★ FG-84M
 - ◎ C68
 - CFD-409

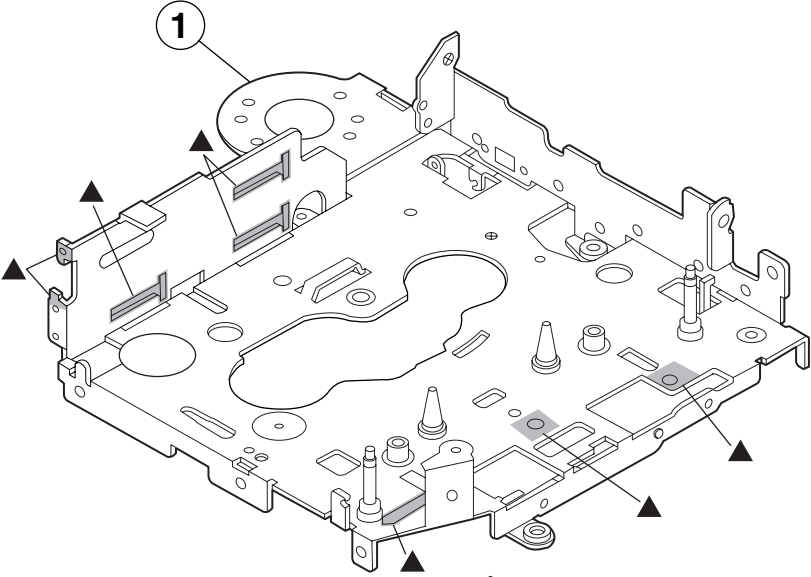

Reverse side

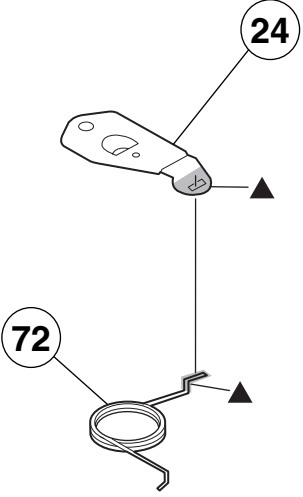
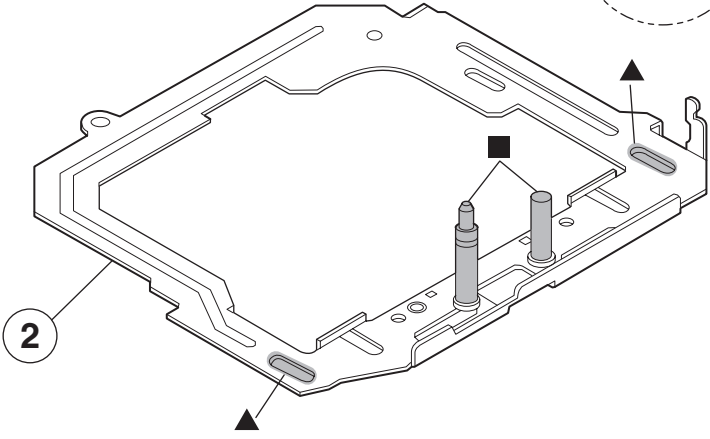
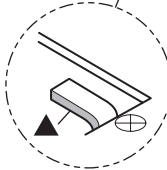
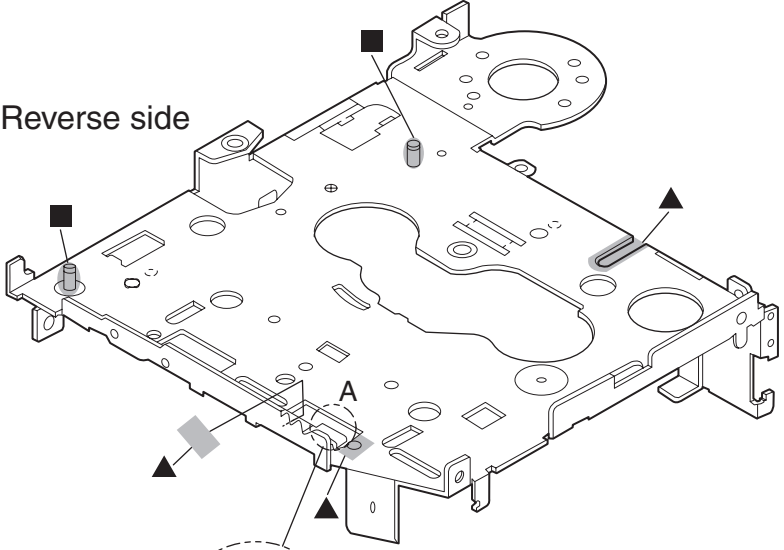

Grease point 2/2

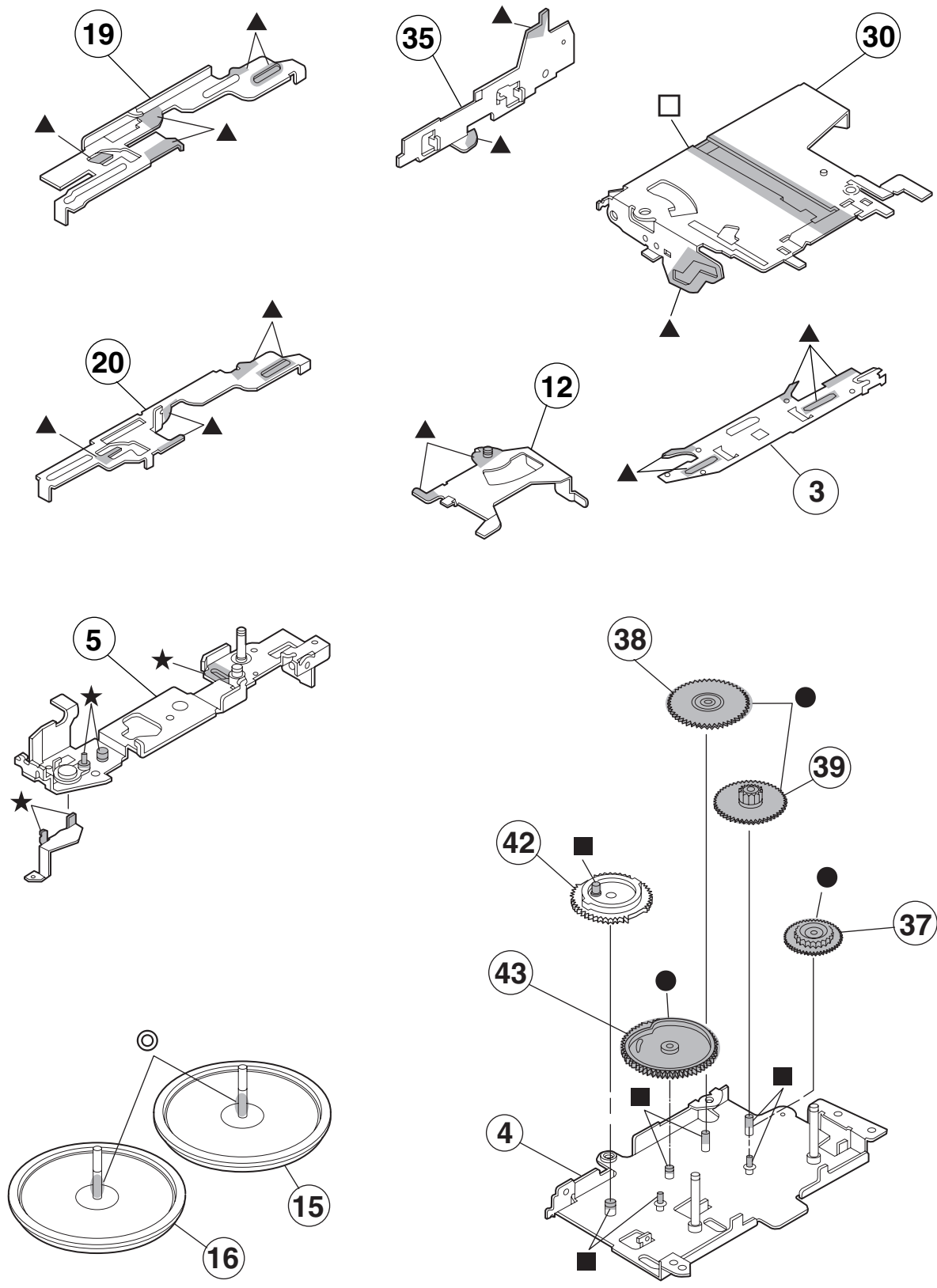

Electrical parts list

Main board

Block No. [0][1][0][0]

△ Symbol No.	Part No.	Part Name	Description	Local
IC701	LC72362N-9B39	IC	Micon	
IC781	AN80T05LF	IC	Regulator	
IC931	LC75421M-X	IC	E. volume	
IC981	LA4743K	POWER IC	Power amp.	
Q1	2SA1706/ST-T	TRANSISTOR		
Q2	KRC102M-T	DIGI TRANSISTOR		
Q3	KTA1267/YG-T	TRANSISTOR		
Q4	KRC102M-T	DIGI TRANSISTOR		
Q5	KRC102M-T	DIGI TRANSISTOR		
Q161	2SD2144S/VW-T	TRANSISTOR		
Q261	2SD2144S/VW-T	TRANSISTOR		
Q701	KTC3199/GL-T	TRANSISTOR		
Q771	KTC3199/GL-T	TRANSISTOR		
Q772	KTC3199/GL-T	TRANSISTOR		
Q781	KRC102M-T	DIGI TRANSISTOR		
Q782	2SA1706/ST-T	TRANSISTOR		
Q783	KRC102M-T	DIGI TRANSISTOR		
Q784	2SA1706/ST-T	TRANSISTOR		
Q789	KRA102M-T	DIGI TRANSISTOR		
Q971	KRC102M-T	DIGI TRANSISTOR		
Q972	KRA102M-T	DIGI TRANSISTOR		
Q987	KRA102M-T	DIGI TRANSISTOR		
Q988	KRC102M-T	DIGI TRANSISTOR		
Q989	KRA102M-T	DIGI TRANSISTOR		
D1	1SS119-041	DIODE		
D2	1SS119-041	DIODE		
D161	1SS119-041	DIODE		
D261	1SS119-041	DIODE		
D704	MTZJ6.2B-T2	Z DIODE		
D705	MTZJ6.2B-T2	Z DIODE		
D706	MTZJ6.2B-T2	Z DIODE		
D707	MTZJ6.2B-T2	Z DIODE		
D708	MTZJ6.2B-T2	Z DIODE		
D709	MTZJ6.2B-T2	Z DIODE		
D711	MTZJ6.2B-T2	Z DIODE		
D713	1SS119-041	DIODE		
D714	1SS119-041	DIODE		
D716	1SS119-041	DIODE		
D718	1SS119-041	DIODE		
D771	MTZJ9.1C-T2	Z DIODE		
D781	1SS119-041	DIODE		
D782	1SS119-041	DIODE		
D784	1A3G-T1	DIODE		
D785	1A3G-T1	DIODE		
D786	1A3G-T1	DIODE		
D791	1SS119-041	DIODE		
D792	1SS119-041	DIODE		
D961	RB721Q-40-T2	DIODE		
D973	1SS119-041	DIODE		
D974	1SS119-041	DIODE		
D981	1N5401-TM	SI DIODE		
D990	MTZJ11B-T2	Z DIODE		
C2	QDX11EK-223Z	C CAPACITOR	0.022uF 25V K	
C3	QEKJ1HM-104Z	E CAPACITOR	0.1uF 50V M	
C4	QEKJ1HM-104Z	E CAPACITOR	0.1uF 50V M	
C5	QEKJ1CM-106Z	E CAPACITOR	10uF 16V M	
C6	QDX11EK-223Z	C CAPACITOR	0.022uF 25V K	
C7	QDX11EK-223Z	C CAPACITOR	0.022uF 25V K	
C8	QERF1HM-104Z	E CAPACITOR	0.1uF 50V M	
C9	QDYB1CM-103Y	C CAPACITOR	0.01uF 16V M	
C11	QDYB1CM-103Y	C CAPACITOR	0.01uF 16V M	
C12	QCBB1HK-271Y	C CAPACITOR	270pF 50V K	
C15	QDYB1CM-103Y	C CAPACITOR	0.01uF 16V M	
C131	QERF1HM-105Z	E CAPACITOR	1uF 50V M	
C132	QERF1HM-105Z	E CAPACITOR	1uF 50V M	
C134	QFV61HJ-823Z	MF CAPACITOR	0.082uF 50V J	
C135	QFV61HJ-823Z	MF CAPACITOR	0.082uF 50V J	
C136	QFVD1HJ-154Z	MF CAPACITOR	0.15uF 50V J	

△ Symbol No.	Part No.	Part Name	Description	Local
C137	QFVD1HJ-154Z	MF CAPACITOR	0.15uF 50V J	
C138	QCFB1HZ-104Y	C CAPACITOR	0.1uF 50V Z	
C150	QERF1HM-225Z	E CAPACITOR	2.2uF 50V M	
C160	QERF1HM-225Z	E CAPACITOR	2.2uF 50V M	
C231	QERF1HM-105Z	E CAPACITOR	1uF 50V M	
C232	QERF1HM-105Z	E CAPACITOR	1uF 50V M	
C234	QFLK1HJ-152Z	M CAPACITOR	1500pF 50V J	
C235	QFV61HJ-823Z	MF CAPACITOR	0.082uF 50V J	
C236	QFV61HJ-823Z	MF CAPACITOR	0.082uF 50V J	
C237	QFVD1HJ-154Z	MF CAPACITOR	0.15uF 50V J	
C238	QFVD1HJ-154Z	MF CAPACITOR	0.15uF 50V J	
C250	QERF1HM-225Z	E CAPACITOR	2.2uF 50V M	
C260	QERF1HM-225Z	E CAPACITOR	2.2uF 50V M	
C701	QDUB1HJ-270Y	C CAPACITOR	27pF 50V J	
C702	QDCB1HJ-220Y	C CAPACITOR	22pF 50V J	
C703	QERF0JM-107Z	E CAPACITOR	100uF 6.3V M	
C704	QFVD1HJ-224Z	MF CAPACITOR	0.22uF 50V J	
C705	QERF1CM-106Z	E CAPACITOR	10uF 16V M	
C706	QDYB1CM-103Y	C CAPACITOR	0.01uF 16V M	
C707	QFV61HJ-103Z	MF CAPACITOR	0.01uF 50V J	
C709	QERF1HM-474Z	E CAPACITOR	0.47uF 50V M	
C710	QCFB1HZ-104Y	C CAPACITOR	0.1uF 50V Z	
C771	QERF1AM-227Z	E CAPACITOR	220uF 10V M	
C772	QERF1HM-225Z	E CAPACITOR	2.2uF 50V M	
C773	QDGB1HK-102Y	C CAPACITOR	1000pF 50V K	
C781	QEKJ1CM-106Z	E CAPACITOR	10uF 16V M	
C783	QETN0JM-228Z	E CAPACITOR	2200uF 6.3V M	
C784	QERF1AM-227Z	E CAPACITOR	220uF 10V M	
C785	QERF1CM-106Z	E CAPACITOR	10uF 16V M	
C786	QERF1AM-227Z	E CAPACITOR	220uF 10V M	
C931	QEKJ1AM-107Z	E CAPACITOR	100uF 10V M	
C932	QCFB1HZ-104Y	C CAPACITOR	0.1uF 50V Z	
C933	QERF1HM-105Z	E CAPACITOR	1uF 50V M	
C934	QERF1CM-226Z	E CAPACITOR	22uF 16V M	
C940	QERF1HM-105Z	E CAPACITOR	1uF 50V M	
C941	QERF1HM-105Z	E CAPACITOR	1uF 50V M	
C942	QFLK1HJ-152Z	M CAPACITOR	1500pF 50V J	
C943	QERF1HM-105Z	E CAPACITOR	1uF 50V M	
C992	QERF1AM-227Z	E CAPACITOR	220uF 10V M	
C974	QFVD1HJ-224Z	MF CAPACITOR	0.22uF 50V J	
C975	QFVD1HJ-224Z	MF CAPACITOR	0.22uF 50V J	
C976	QFVD1HJ-224Z	MF CAPACITOR	0.22uF 50V J	
C977	QFVD1HJ-224Z	MF CAPACITOR	0.22uF 50V J	
C981	QE20615-228	E CAPACITOR	2200uF	
C982	QERF1CM-476Z	E CAPACITOR	47uF 16V M	
C983	QCFB1HZ-104Y	C CAPACITOR	0.1uF 50V Z	
C984	QERF1CM-106Z	E CAPACITOR	10uF 16V M	
C985	QERF1EM-475Z	E CAPACITOR	4.7uF 25V M	
C986	QERF1CM-226Z	E CAPACITOR	22uF 16V M	
C987	QEKJ1CM-106Z	E CAPACITOR	10uF 16V M	
C988	QERF1CM-476Z	E CAPACITOR	47uF 16V M	
C989	QERF1CM-106Z	E CAPACITOR	10uF 16V M	
C990	QCFB1HZ-104Y	C CAPACITOR	0.1uF 50V Z	
C991	QCFB1HZ-104Y	C CAPACITOR	0.1uF 50V Z	
C992	QCFB1HZ-104Y	C CAPACITOR	0.1uF 50V Z	
C993	QCFB1HZ-104Y	C CAPACITOR	0.1uF 50V Z	
C994	QCBB1HK-471Y	C CAPACITOR	470pF 50V K	
C995	QCBB1HK-471Y	C CAPACITOR	470pF 50V K	
C996	QCBB1HK-471Y	C CAPACITOR	470pF 50V K	
C997	QCBB1HK-471Y	C CAPACITOR	470pF 50V K	
R1	QRE141J-100Y	C RESISTOR	10Ω 1/4W J	
R2	QRE141J-102Y	C RESISTOR	1kΩ 1/4W J	
R3	QRE141J-102Y	C RESISTOR	1kΩ 1/4W J	
R4	QRE141J-103Y	C RESISTOR	10kΩ 1/4W J	
R5	QRE141J-102Y	C RESISTOR	1kΩ 1/4W J	
R6	QRE141J-103Y	C RESISTOR	10kΩ 1/4W J	
R9	QRE141J-103Y	C RESISTOR	10kΩ 1/4W J	
R10	QRE141J-103Y	C RESISTOR	10kΩ 1/4W J	
R14	QRE141J-822Y	C RESISTOR	8.2kΩ 1/4W J	
R15	QRE141J-223Y	C RESISTOR	22kΩ 1/4W J	
R17	QRE141J-222Y	C RESISTOR	2.2kΩ 1/4W J	
R51	QRE141J-471Y	C RESISTOR	470Ω 1/4W J	
R52	QRE141J-752Y	C RESISTOR	7.5kΩ 1/4W J	
R61	QRE141J-471Y	C RESISTOR	470Ω 1/4W J	

△ Symbol No.	Part No.	Part Name	Description	Local	△ Symbol No.	Part No.	Part Name	Description	Local
R62	QRE141J-752Y	C RESISTOR	7.5kΩ 1/4W J		X701	QAX0406-001Z	CRYSTAL	4.500MHz	
R131	QRE141J-392Y	C RESISTOR	3.9kΩ 1/4W J		Mecha control board				
R132	QRE141J-752Y	C RESISTOR	7.5kΩ 1/4W J		Block No. [0][2][0][0]				
R163	QRE141J-821Y	C RESISTOR	820Ω 1/4W J		△ Symbol No.	Part No.	Part Name	Description	Local
R164	QRE141J-101Y	C RESISTOR	100Ω 1/4W J		IC651	LC75823W	IC	LCD driver	
R165	QRE141J-222Y	C RESISTOR	2.2kΩ 1/4W J		D601	SML-310LT/MN/-X	LED		
R231	QRE141J-392Y	C RESISTOR	3.9kΩ 1/4W J		D602	LNJ308G81/1-3/X	LED		
R232	QRE141J-752Y	C RESISTOR	7.5kΩ 1/4W J		D603	LNJ308G81/1-3/X	LED		
R263	QRE141J-821Y	C RESISTOR	820Ω 1/4W J		D604	LNJ308G81/1-3/X	LED		
R264	QRE141J-101Y	C RESISTOR	100Ω 1/4W J		D605	LNJ308G81/1-3/X	LED		
R265	QRE141J-222Y	C RESISTOR	2.2kΩ 1/4W J		D606	LNJ308G81/1-3/X	LED		
R702	QRE141J-473Y	C RESISTOR	47kΩ 1/4W J		D607	LNJ308G81/1-3/X	LED		
R703	QRE141J-473Y	C RESISTOR	47kΩ 1/4W J		D608	LNJ308G81/1-3/X	LED		
R704	QRE141J-103Y	C RESISTOR	10kΩ 1/4W J		D610	LNJ308G81/1-3/X	LED		
R705	QRE141J-473Y	C RESISTOR	47kΩ 1/4W J		D611	LNJ308G81/1-3/X	LED		
R707	QRE141J-473Y	C RESISTOR	47kΩ 1/4W J		D612	LNJ308G81/1-3/X	LED		
R708	QRE141J-473Y	C RESISTOR	47kΩ 1/4W J		D613	LNJ308G81/1-3/X	LED		
R709	QRE141J-472Y	C RESISTOR	4.7kΩ 1/4W J		D614	LNJ308G81/1-3/X	LED		
R710	QRE141J-472Y	C RESISTOR	4.7kΩ 1/4W J		D615	LNJ308G81/1-3/X	LED		
R712	QRE141J-472Y	C RESISTOR	4.7kΩ 1/4W J		D616	LNJ308G81/1-3/X	LED		
R713	QRE141J-472Y	C RESISTOR	4.7kΩ 1/4W J		D617	LNJ308G81/1-3/X	LED		
R714	QRE141J-472Y	C RESISTOR	4.7kΩ 1/4W J		D618	LNJ308G81/1-3/X	LED		
R715	QRE141J-222Y	C RESISTOR	2.2kΩ 1/4W J		D619	LNJ308G81/1-3/X	LED		
R718	QRE141J-332Y	C RESISTOR	3.3kΩ 1/4W J		D620	LNJ308G81/1-3/X	LED		
R719	QRE141J-332Y	C RESISTOR	3.3kΩ 1/4W J		C651	NCB31EK-103X	C CAPACITOR	0.01uF 25V K	
R720	QRE141J-332Y	C RESISTOR	3.3kΩ 1/4W J		C652	NBE20JM-475X	TA E CAPACITOR	4.7uF 6.3V M	
R721	QRE141J-332Y	C RESISTOR	3.3kΩ 1/4W J		C653	NCB31HK-681X	C CAPACITOR	680pF 50V K	
R722	QRE141J-332Y	C RESISTOR	3.3kΩ 1/4W J		R601	NRSA63J-681X	MG RESISTOR	680Ω 1/16W J	
R724	QRE141J-472Y	C RESISTOR	4.7kΩ 1/4W J		R602	NRSA63J-561X	MG RESISTOR	560Ω 1/16W J	
R725	QRE141J-473Y	C RESISTOR	47kΩ 1/4W J		R603	NRSA63J-681X	MG RESISTOR	680Ω 1/16W J	
R726	QRE141J-473Y	C RESISTOR	47kΩ 1/4W J		R604	NRSA63J-911X	MG RESISTOR	910Ω 1/16W J	
R727	QRE141J-473Y	C RESISTOR	47kΩ 1/4W J		R605	NRSA63J-122X	MG RESISTOR	1.2kΩ 1/16W J	
R771	QRE141J-472Y	C RESISTOR	4.7kΩ 1/4W J		R607	NRSA63J-681X	MG RESISTOR	680Ω 1/16W J	
R772	QRE141J-103Y	C RESISTOR	10kΩ 1/4W J		R608	NRSA63J-561X	MG RESISTOR	560Ω 1/16W J	
R773	QRE141J-102Y	C RESISTOR	1kΩ 1/4W J		R609	NRSA63J-681X	MG RESISTOR	680Ω 1/16W J	
R774	QRE141J-152Y	C RESISTOR	1.5kΩ 1/4W J		R610	NRSA63J-911X	MG RESISTOR	910Ω 1/16W J	
R783	QRE141J-473Y	C RESISTOR	47kΩ 1/4W J		R611	NRSA63J-122X	MG RESISTOR	1.2kΩ 1/16W J	
R784	QRE141J-102Y	C RESISTOR	1kΩ 1/4W J		R613	NRSA63J-681X	MG RESISTOR	680Ω 1/16W J	
R785	QRE141J-473Y	C RESISTOR	47kΩ 1/4W J		R614	NRSA63J-561X	MG RESISTOR	560Ω 1/16W J	
R786	QRE141J-102Y	C RESISTOR	1kΩ 1/4W J		R615	NRSA63J-681X	MG RESISTOR	680Ω 1/16W J	
R787	QRE141J-101Y	C RESISTOR	100Ω 1/4W J		R616	NRSA63J-911X	MG RESISTOR	910Ω 1/16W J	
R788	QRE141J-242Y	C RESISTOR	2.4kΩ 1/4W J		R617	NRSA63J-122X	MG RESISTOR	1.2kΩ 1/16W J	
R789	QRE141J-104Y	C RESISTOR	100kΩ 1/4W J		R618	NRSA63J-152X	MG RESISTOR	1.5kΩ 1/16W J	
R790	QRE141J-474Y	C RESISTOR	470kΩ 1/4W J		R635	NRSA02J-821X	MG RESISTOR	820Ω 1/10W J	
R792	QRE141J-6R8Y	C RESISTOR	6.8Ω 1/4W J		R636	NRSA02J-821X	MG RESISTOR	820Ω 1/10W J	
R795	QRE141J-183Y	C RESISTOR	18kΩ 1/4W J		R637	NRSA02J-152X	MG RESISTOR	1.5kΩ 1/10W J	
R796	QRE141J-473Y	C RESISTOR	47kΩ 1/4W J		R638	NRSA02J-821X	MG RESISTOR	820Ω 1/10W J	
R797	QRE141J-123Y	C RESISTOR	12kΩ 1/4W J		R639	NRSA02J-821X	MG RESISTOR	820Ω 1/10W J	
R931	QRE141J-100Y	C RESISTOR	10Ω 1/4W J		R640	NRSA02J-102X	MG RESISTOR	1kΩ 1/10W J	
R941	QRE141J-332Y	C RESISTOR	3.3kΩ 1/4W J		R641	NRSA02J-182X	MG RESISTOR	1.8kΩ 1/10W J	
R972	QRE141J-272Y	C RESISTOR	2.7kΩ 1/4W J		R642	NRSA02J-821X	MG RESISTOR	820Ω 1/10W J	
R973	QRE141J-472Y	C RESISTOR	4.7kΩ 1/4W J		R643	NRSA02J-821X	MG RESISTOR	820Ω 1/10W J	
R985	QRE141J-472Y	C RESISTOR	4.7kΩ 1/4W J		R644	NRSA02J-561X	MG RESISTOR	560Ω 1/10W J	
R990	QRE141J-103Y	C RESISTOR	10kΩ 1/4W J		R645	NRSA02J-621X	MG RESISTOR	620Ω 1/10W J	
R991	QRE141J-273Y	C RESISTOR	27kΩ 1/4W J		R646	NRSA02J-821X	MG RESISTOR	820Ω 1/10W J	
R992	QRE141J-273Y	C RESISTOR	27kΩ 1/4W J		R647	NRSA02J-821X	MG RESISTOR	820Ω 1/10W J	
R993	QRE141J-273Y	C RESISTOR	27kΩ 1/4W J		R648	NRSA02J-821X	MG RESISTOR	820Ω 1/10W J	
R994	QRE141J-273Y	C RESISTOR	27kΩ 1/4W J		R649	NRSA02J-152X	MG RESISTOR	1.5kΩ 1/10W J	
R996	QRE141J-473Y	C RESISTOR	47kΩ 1/4W J		R651	NRSA02J-152X	MG RESISTOR	1.5kΩ 1/10W J	
R997	QRE141J-473Y	C RESISTOR	47kΩ 1/4W J		R652	NRSA02J-473X	MG RESISTOR	47kΩ 1/10W J	
R998	QRE141J-473Y	C RESISTOR	47kΩ 1/4W J		R653	NRSA02J-184X	MG RESISTOR	180kΩ 1/10W J	
R999	QRE141J-473Y	C RESISTOR	47kΩ 1/4W J		R654	NRSA02J-103X	MG RESISTOR	10kΩ 1/10W J	
					R655	NRSA02J-103X	MG RESISTOR	10kΩ 1/10W J	
					R656	NRSA02J-103X	MG RESISTOR	10kΩ 1/10W J	
L1	QQL231K-4R7Y	INDUCTOR I/M	4.7uH K		CP701	VMC0335-001	PANEL CONNECTOR		
L781	QQL231K-470Y	INDUCTOR I/M	47uH K		PL601	QLL0151-001	LAMP		
L782	QQL231K-470Y	INDUCTOR I/M	47uH K						
L783	QQL231K-470Y	INDUCTOR I/M	47uH K						
L981	QQR1367-001	CHOKE COIL							
	VYH7653-002	IC HOLDER							
CJ701	VMC0334-001	CONNECTOR							
CJ921	QNN0519-001	PIN JACK							
CN721	QGB1214J1-06S	CONNECTOR	B-B (1-6)						
CN901	QGB1214J1-06S	CONNECTOR	B-B (1-6)						
CP981	QNZ0611-001	16P CONNECTOR							
J1	QNZ0009-001	CAR ANT JACK							
TU1	QAU0281-001	TUNER PACK							

△ Symbol No.	Part No.	Part Name	Description	Local
PL603	QLL0151-001	LAMP		
S601	NSW0124-001X	TACT SW		
S602	NSW0124-001X	TACT SW		
S603	NSW0124-001X	TACT SW		
S604	NSW0124-001X	TACT SW		
S605	NSW0124-001X	TACT SW		
S606	NSW0124-001X	TACT SW		
S608	NSW0124-001X	TACT SW		
S609	NSW0124-001X	TACT SW		
S610	NSW0124-001X	TACT SW		
S611	NSW0124-001X	TACT SW		
S612	NSW0124-001X	TACT SW		
S614	NSW0124-001X	TACT SW		
S615	NSW0124-001X	TACT SW		
S616	NSW0124-001X	TACT SW		
S617	NSW0124-001X	TACT SW		
S618	NSW0124-001X	TACT SW		
S619	NSW0124-001X	TACT SW		
S620	NSW0124-001X	TACT SW		
S621	NSW0124-001X	TACT SW		

Front board

Block No. [0][3][0][0]

△ Symbol No.	Part No.	Part Name	Description	Local
IC901	UPC1228HA	IC	Head amp	
C101	QDGB1HK-821Y	C CAPACITOR	820pF 50V K	
C102	QEKJ1HM-474Z	E CAPACITOR	0.47uF 50V M	
C103	QCBB1HK-101Y	C CAPACITOR	100pF 50V K	
C104	QEKJ0JM-476Z	E CAPACITOR	47uF 6.3V M	
C105	QFV61HJ-103Z	MF CAPACITOR	0.01uF 50V J	
C201	QDGB1HK-821Y	C CAPACITOR	820pF 50V K	
C202	QERF1HM-474Z	E CAPACITOR	0.47uF 50V M	
C203	QCBB1HK-101Y	C CAPACITOR	100pF 50V K	
C204	QEKJ0JM-476Z	E CAPACITOR	47uF 6.3V M	
C205	QFV61HJ-103Z	MF CAPACITOR	0.01uF 50V J	
C901	QEKJ1AM-107Z	E CAPACITOR	100uF 10V M	
R101	QRE141J-153Y	C RESISTOR	15kΩ 1/4W J	
R103	QRE141J-101Y	C RESISTOR	100Ω 1/4W J	
R104	QRE141J-334Y	C RESISTOR	330kΩ 1/4W J	
R201	QRE141J-153Y	C RESISTOR	15kΩ 1/4W J	
R203	QRE141J-101Y	C RESISTOR	100Ω 1/4W J	
R204	QRE141J-334Y	C RESISTOR	330kΩ 1/4W J	
R901	QRE141J-101Y	C RESISTOR	100Ω 1/4W J	
CJ901	QGA2002C1-05	CONNECTOR	W-B (1-5)	
CP721	QGB1214K1-06S	CONNECTOR	B-B (1-6)	
CP722	QGA2002F1-06	CONNECTOR	W-B (1-6)	
CP901	QGB1214K1-06S	CONNECTOR	B-B (1-6)	

<MEMO>

Packing materials and accessories parts list

Block No. M 3 M M

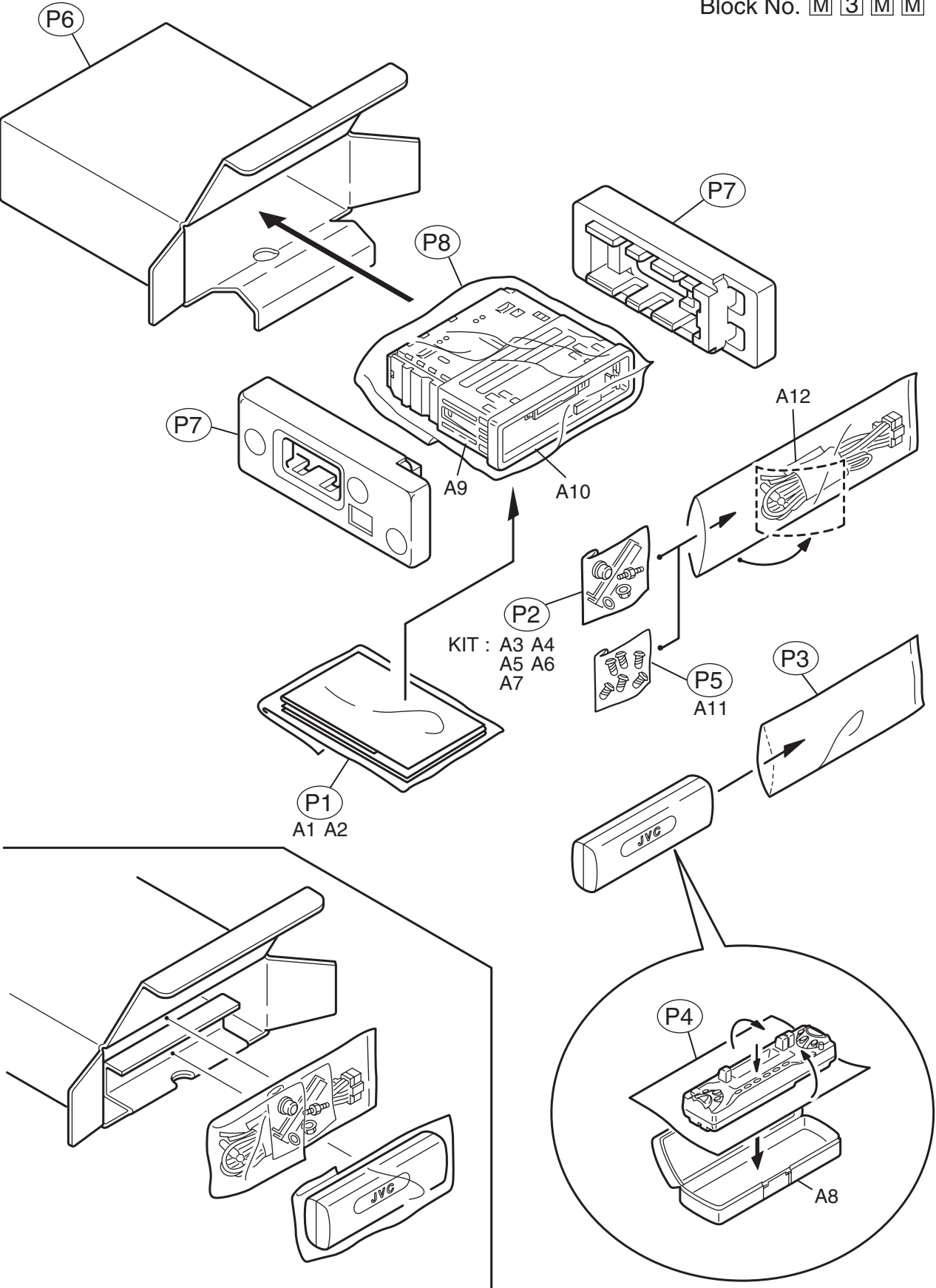

Packing and accessories

Block No. [M][3][M][M]

△ Symbol No.	Part No.	Part Name	Description	Local
A 1	GET0178-001A	INST BOOK	INA	
A 2	GET0178-002A	INSTALL MANUAL	INA	
A 3	VKZ4027-202	PLUG NUT		
A 4	VKH4871-001SS	MOUNT BOLT		
A 5	VKZ4328-001	LOCK NUT		
A 6	WNS5000Z	WASHER		
A 7	GE40130-001A	HOOK	(x2)	
A 8	FSJB3002-30C	HARD CASE		
A 9	GE20137-003A	MOUNTING SLEEVE		
A 10	GE20135-006A	TRIM PLATE		
A 11	QYSDSP5008Z	SCREW	M5 x 8mm(x6)	
A 12	QAM0013-006	16P CORD ASSY		
KIT	KSFX480-SCREW1	SCREW PARTS KIT	A3 to A7	
P 1	FSPG4002-001	POLY BAG		
P 2	QPA00801205	POLY BAG	8cm x 12cm	
P 3	QPA01003003	POLY BAG	10cm x 30cm	
P 4	FSYH4036-068	SHEET		
P 5	QPA00801205	POLY BAG	8cm x 12cm	
P 6	GE31003-001A	CARTON		
P 7	GE10047-001A	EPS CUSHION	(x2)	
P 8	QPC03004315P	POLY BAG	30cm x 43cm	